

Operator's Manual



Label Printer

MACH2

Family	Type
MACH	MACH2/200
	MACH2/300

Edition: 02/2017 - **Part No.** 9009976

Copyright

This documentation as well as translation hereof are property of cab Produkttechnik GmbH & Co. KG.

The replication, conversion, duplication or divulgement of the whole manual or parts of it for other intentions than its original intended purpose demand the previous written authorization by cab Produkttechnik GmbH & Co. KG.

Trademark

Windows is a registered trademark of the Microsoft Corporation.

Editor

Regarding questions or comments please contact cab Produkt-technik GmbH & Co. KG.

Topicality

Due to the constant further development of our products discrepancies between documentation and product can occur.

Please check www.cab.de for the latest update.

Terms and conditions

Deliveries and performances are effected under the General conditions of sale of cab Produkttechnik GmbH & Co. KG.

Germany

cab Produkttechnik
GmbH & Co KG
Postfach 1904
D-76007 Karlsruhe
Wilhelm-Schickard-Str. 14
D-76131 Karlsruhe
Telefon +49 721 6626-0
Telefax +49 721 6626-249
www.cab.de
info@cab.de

France

cab technologies s.a.r.l.
F-67350 Niedermodern
Téléphone +33 388 722 501
www.cab.de/fr
info.fr@cab.de

USA

cab Technology Inc.
Tyngsboro MA, 01879
Phone +1 978 649 0293
www.cab.de/us
info.us@cab.de

Asia 亚洲

cab Technology Co., Ltd.
希愛比科技股份有限公司
Junghe, Taipei, Taiwan
Phone +886 2 8227 3966
www.cab.de/tw
info.asia@cab.de

China 中国

cab (Shanghai)Trading Co., Ltd.
乾博(上海)貿易有限公司
Phone +86 21 6236-3161
www.cab.de/cn
info.cn@cab.de

Representatives in other countries on request

1	Introduction	4
1.1	Instructions.....	4
1.2	Intended Use.....	4
1.3	Safety Instructions.....	5
1.4	Environment.....	5
2	Device Overview.....	6
2.1	Unpacking and Box Content	6
2.2	Device Views.....	7
2.2.1	Front View	7
2.2.2	Rear View	7
2.2.3	Bottom View	8
2.2.4	The Internal View of Printer	8
2.2.5	The Printing Mechanism.....	9
3	Connecting and switching on the Device	10
3.1	Connecting the Printer	10
3.1.1	Connecting to the Power Supply	10
3.1.2	Connecting to a Computer.....	11
3.2	Switching on the Printer	11
4	Loading Material.....	12
4.1	Open the Printer.....	12
4.2	Loading / Replacing the Ribbon on the Printer	12
4.2.1	Ribbon Module Installation	12
4.2.2	Ribbon Supply Module	13
4.2.3	Ribbon Rewind Module	14
4.3	Loading / Replacing the Label Stock on the Printer	15
4.4	Function Test.....	16
5	Installing Software and configure the Printer	17
5.1	Installing the Printer Driver.....	17
5.2	Installing Labeling Software cablabel S3 Lite.....	18
5.3	Configuration of Printer Settings	19
6	Printer Setting and Control	21
6.1	Operation Panel	21
6.2	LCD Interface – Introduction	22
6.3	Ethernet Setting	28
6.4	LCD Password	30
6.5	LCD Interface – Function	32
6.6	Label Calibration and Self Test	35
7	Maintenance	37
7.1	Cleaning.....	37
7.1.1	General Cleaning Information.....	37
7.1.2	Cleaning the Print Head	37
7.2	Error Alerts	38
7.3	Troubleshooting.....	39
8	Accessories	40
8.1	Preparation Steps	40
8.2	Installing the Present Sensor	42
8.3	Installing the Cutter	47
9	Appendix.....	51
9.1	Technical Data.....	51
9.2	Interface	53
9.3	Reference to the EU Declaration of Conformity	54
9.4	FCC.....	54
10	Index.....	55

1.1 Instructions

Important information and instructions in this documentation are designated as follows:

**Danger!**

Draws attention to an exceptionally great, imminent danger to your health or life due to hazardous voltages.

**Danger!**

Draws attention to a danger with high risk which, if not avoided, may result in death or serious injury.

**Warning!**

Draws attention to a danger with medium risk which, if not avoided, may result in death or serious injury.

**Caution!**

Draws attention to a danger with low risk which, if not avoided, may result in minor or moderate injury.

**Attention!**

Draws attention to possible dangers, material damage or loss of quality.

**Note!**

Advices to make work routine easier or on important steps to be carried out.

**Environment!**

Gives you tips on protecting the environment.



Handling instruction



Reference to section, position, illustration number or document.



Option (accessories, peripheral equipment, special fittings).

Time

Information in the display.

1.2 Intended Use

- The device is manufactured in accordance with the current technological status and the recognized safety rules. However, danger to the life and limb of the user or third parties and/or damage to the device and other tangible assets can arise during use.
- The device may only be used for its intended purpose and if it is in perfect working order, and it must be used with regard to safety and dangers as stated in the operating manual.
- The device printer is intended exclusively for printing suitable materials that have been approved by the manufacturer. Any other use or use going beyond this shall be regarded as improper use. The manufacturer/supplier shall not be liable for damage resulting from unauthorized use; the user shall bear the risk alone.
- Usage for the intended purpose also includes complying with the operating manual, including the manufacturer's maintenance recommendations and specifications.

**Note!**

The complete documentation is included in the scope of delivery on DVD, and can also currently be found in the Internet.

1.3 Safety Instructions

- The device is configured for voltages of 100 to 240 V AC. It only has to be plugged into a grounded socket.
- Only connect the device to other devices which have a protective low voltage.
- Switch off all affected devices (computer, printer, accessories) before connecting or disconnecting.
- The device may only be used in a dry environment, do not expose it to moisture (sprays of water, mists, etc.).
- Do not use the device in an explosive atmosphere.
- Do not use the device close to high-voltage power lines.
- If the device is operated with the cover open, ensure that people's clothing, hair, jewelry etc. do not come into contact with the exposed rotating parts.
- The device or parts of it, especially the printheads can become hot while printing. Do not touch during operation, and allow to cool down before changing material and before disassembly.
- Risk of crushing when closing the cover. Touch the cover at the outside only. Do not reach into the swivel range of the cover.
- Perform only those actions described in this operating manual.
Work going beyond this may only be performed by trained personnel or service technicians.
- Unauthorized interference with electronic modules or their software can cause malfunctions.
- Other unauthorized work on or modifications to the device can also endanger operational safety.
- Always have service work done in a qualified workshop, where the personnel have the technical knowledge and tools required to do the necessary work.
- There are various warning stickers on the device. They draw your attention to dangers.
Warning stickers must therefore not be removed, as then you and other people cannot be aware of dangers and may be injured.
- The maximum sound pressure level LpA is less than 70 dB(A).



Danger!

Danger to life and limb from power supply.

- ▶ **Do not open the device casing.**



Warning!

This is a class A product. In a domestic environment this product may cause radio interference in which case the user may be required to take adequate measures.

1.4 Environment



Obsolete devices contain valuable recyclable materials that should be sent for recycling.

- ▶ Send to suitable collection points, separately from residual waste.

The modular construction of the printer enables it to be easily disassembled into its component parts.

- ▶ Send the parts for recycling.



The electronic circuit board of the device is equipped with a lithium battery.

- ▶ Take old batteries to collection boxes in shops or public waste disposal centers.

2.1 Unpacking and Box Content

1. Lift the printer out of the box via the straps.
2. Check printer for damage which may have occurred during transport.
3. Set up printer on a level surface.
4. Check delivery for completeness.

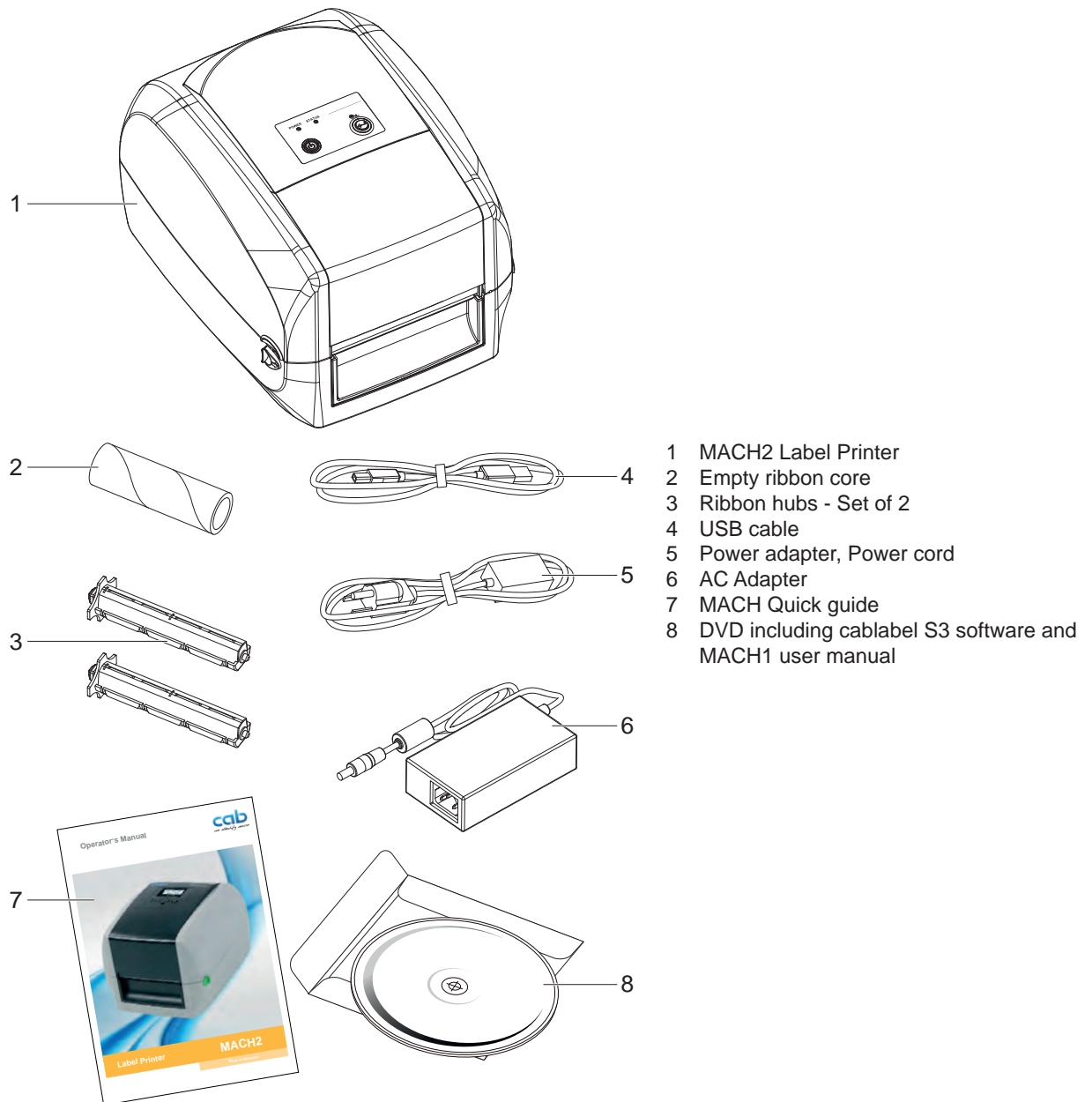

Fig. 1 Box Content



Note!

Please keep the original packaging in case the printer must be returned.



Attention!

The device and printing materials will be damaged by moisture and wetness.

► Set up transfer printers only in dry locations protected from splash water.

2.2 Device Views

2.2.1 Front View

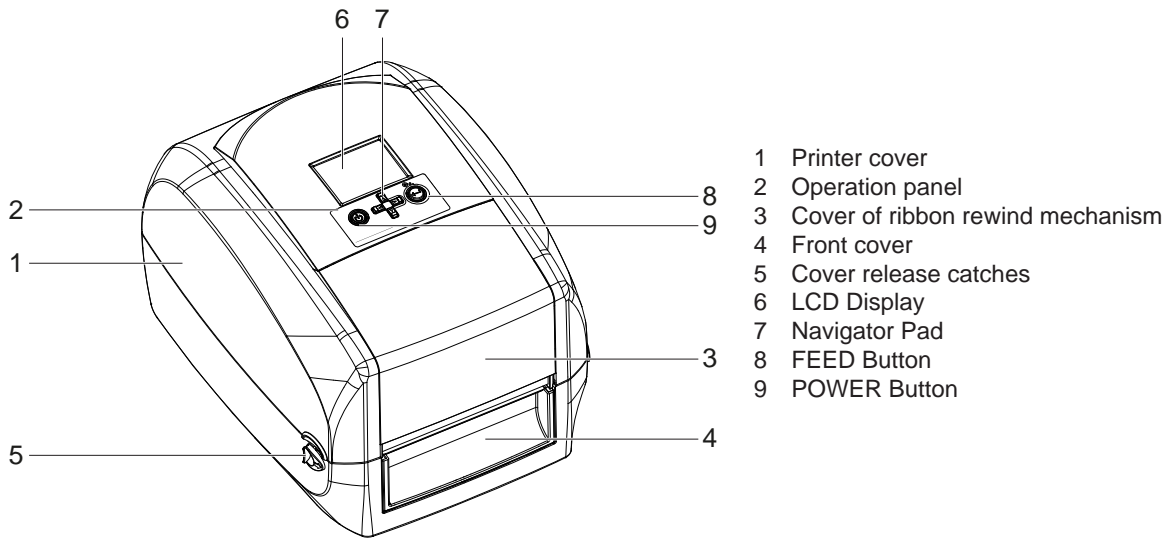

Fig. 2 Front View

2.2.2 Rear View

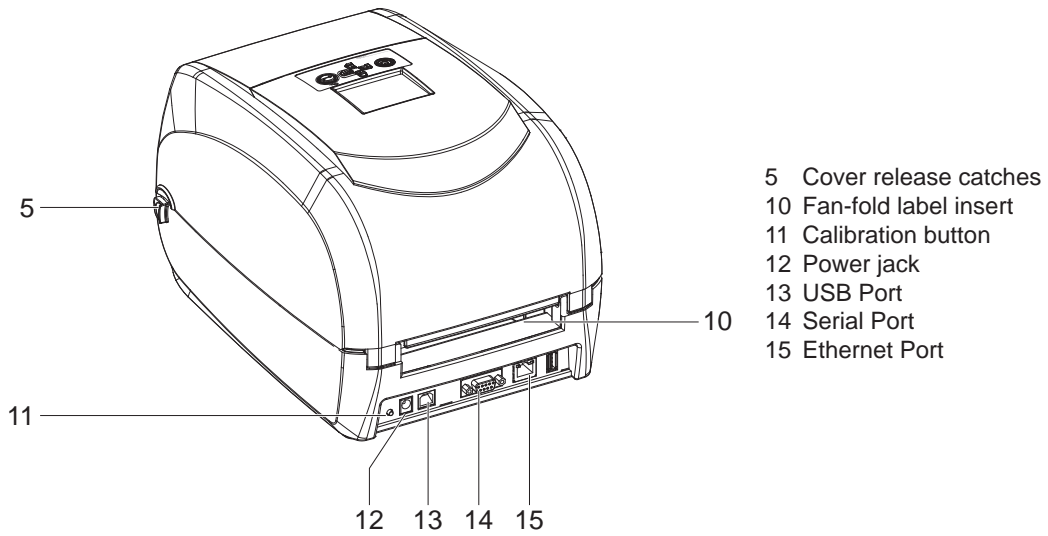
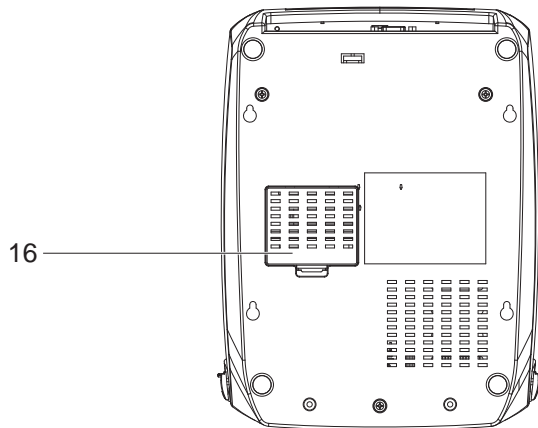

Fig. 3 Rear View

2.2.3 Bottom View



16 Cover of the module connection jacks

Fig. 4 Bottom View



Note!

The cut-outs at the device bottom are not intended for wall-mount use.

2.2.4 The Internal View of Printer

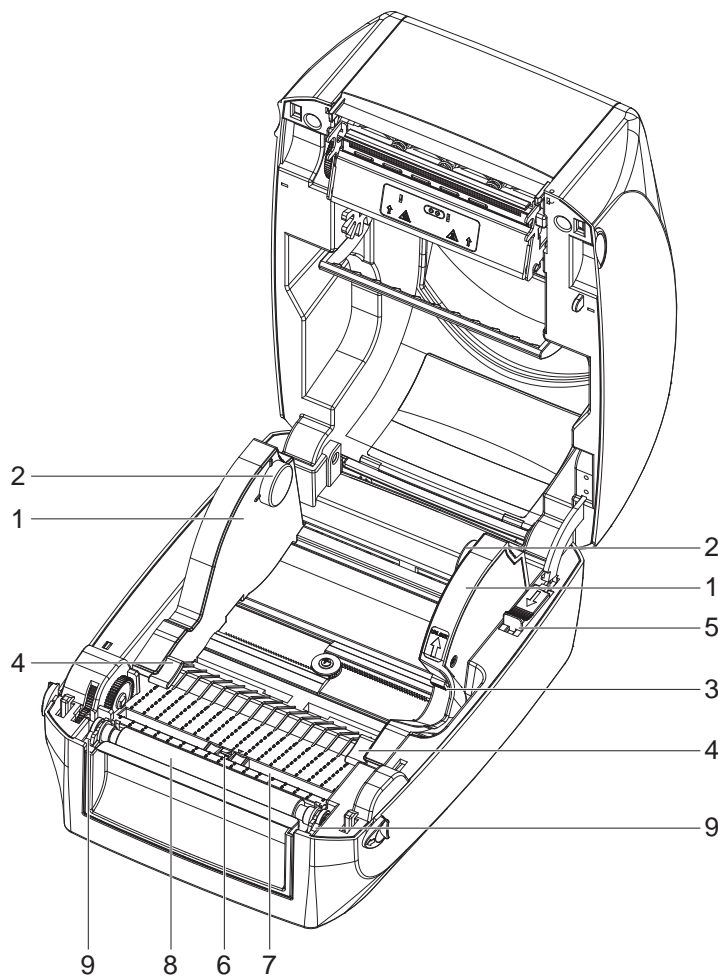

- 1 Label guide plate
- 2 Label supply hub
- 3 Release catch for opening the label supply hub
- 4 Label Guide
- 5 Release catch for closing the printer cover
- 6 Label sensor
- 7 Guide track
- 8 Platen
- 9 Platen lockers

Fig. 5 Internal View

2.2.5 The Printing Mechanism

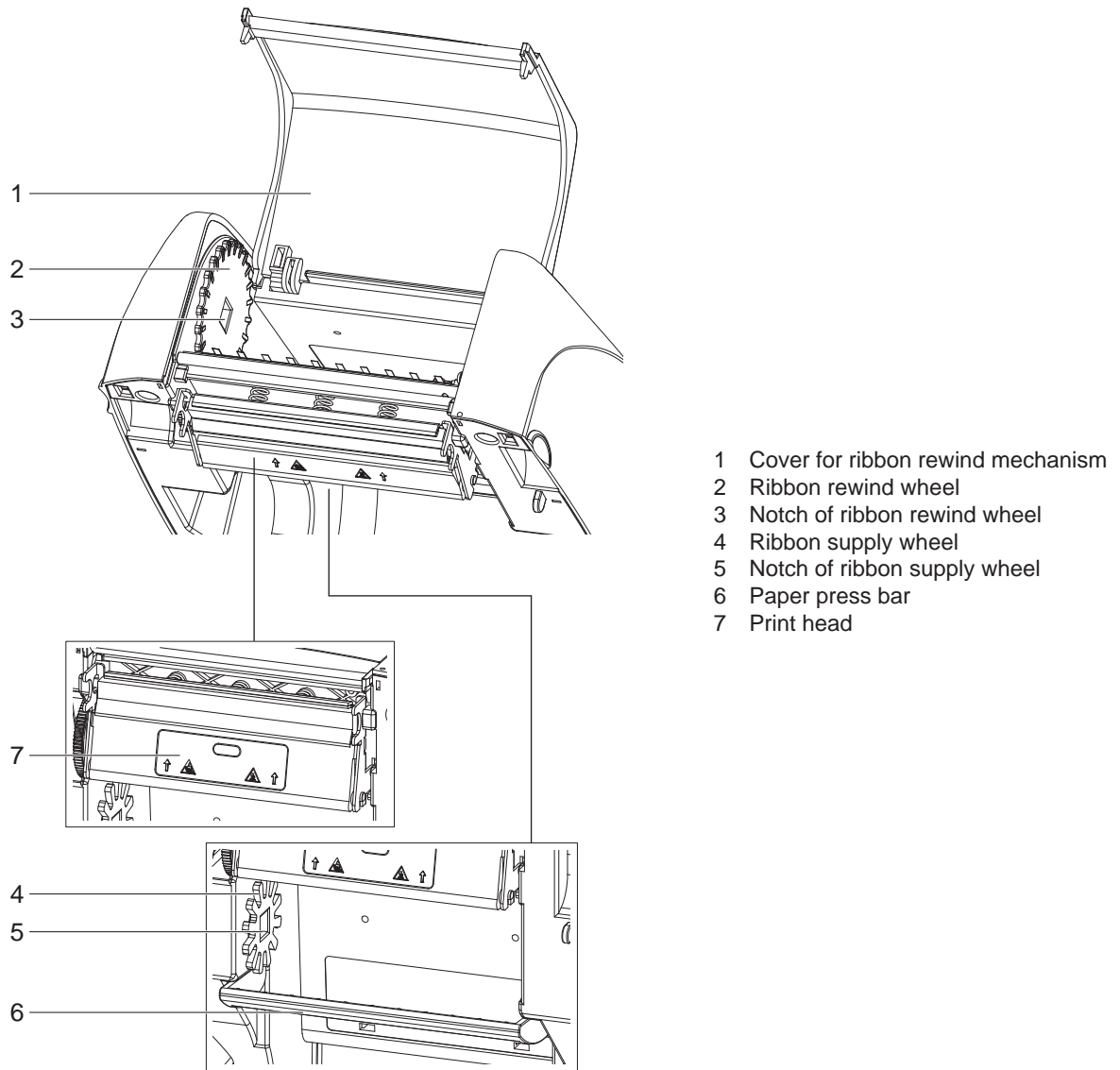

Fig. 6 Printing Mechanism

3.1 Connecting the Printer

**Attention!**

Risk of damage to devices!

Inadequate or no grounding can damage devices and cause malfunctions during operation.

► Ensure that all computers and cables connected to the printer are grounded.

**Note!**

The printer is equipped with a wide area power unit. The device can be operated with a supply voltage of 230 V~/50 Hz or 115 V~/60 Hz without adjustment.

3.1.1 Connecting to the Power Supply

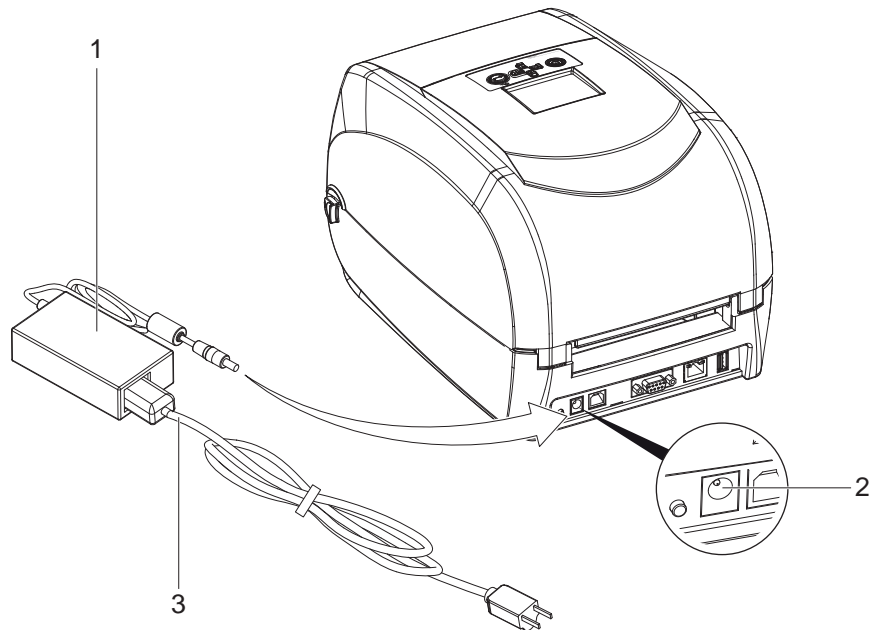

Fig. 7 Connecting Printer to the Power Supply

1. Check that the device is switched off.
2. Plug the jack of the AC adapter (1) into the power connection socket (2).
3. Plug the power cable (3) into the AC adapter (1).
4. Plug the power cable (3) into a grounded socket.

**Note!**

The design of the power plug differs according to the intended country of use.

3.1.2 Connecting to a Computer



Attention!

Loss of material!

The RS-232 interface is unsuitable for fast transmission of changing data.

- ▶ Use USB or Ethernet interface for print operation.
- ▶ Use the RS-232 interface only for setting up the printer.

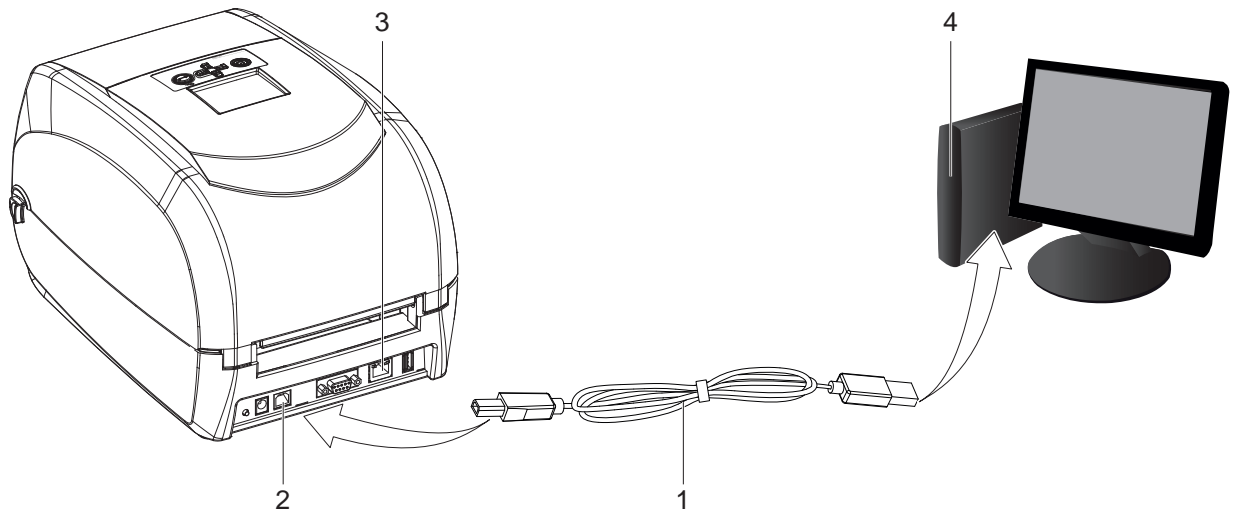

Fig. 8 Connect the printer to the computer via USB or Ethernet.

- ▶ Plug the USB cable (1) into the USB interface (2) on the printer.
- or
- ▶ Plug the Ethernet cable into the Ethernet interface (3) on the printer.
- ▶ Connect the cable to the corresponding interface on the computer (4).

3.2 Switching on the Printer

When all connections have been made correctly:

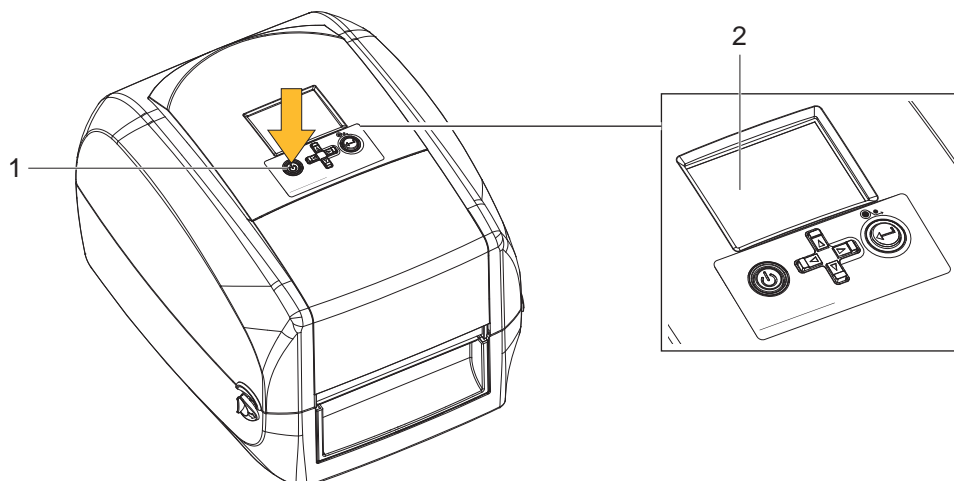

Fig. 9 Switching on the Printer

- ▶ Switch the printer on at the POWER button (1).
- The printer performs a system test, and then the system status is shown in the LCD display (2).

4.1 Open the Printer

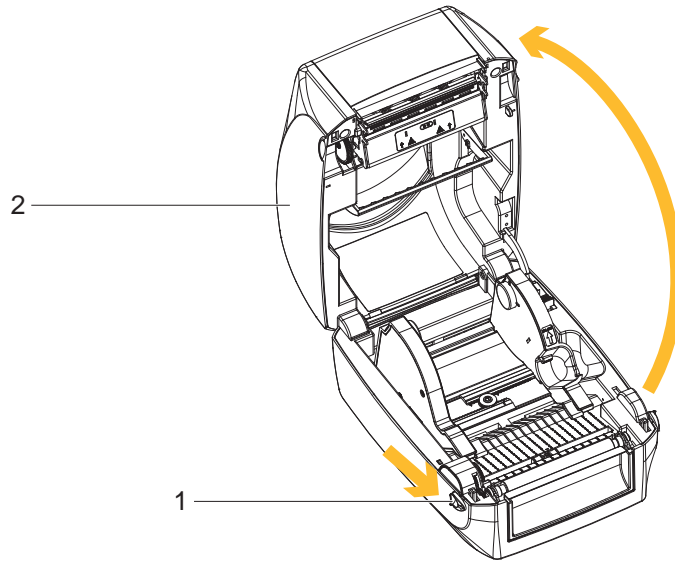

Fig. 10 Open the Printer

1. Place the printer on a flat surface.
2. Pull the cover release catches (1) on both sides of the printer.
3. Raise the cover of the casing (2) and lock it into the catch.



Note!

The printing mechanism is lifted up with the printer cover.

4.2 Loading / Replacing the Ribbon on the Printer

4.2.1 Ribbon Module Installation

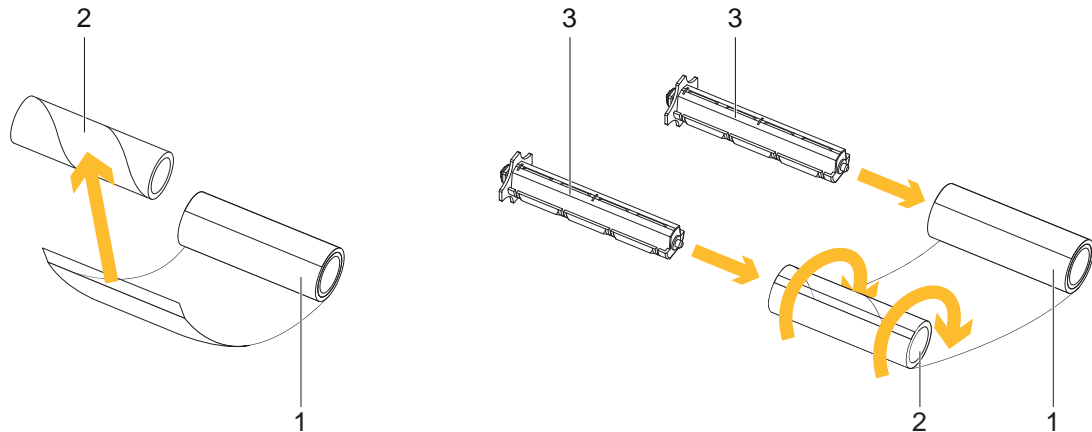

Fig. 11 Ribbon Module Installation

1. Attach the ribbon (1) to the empty ribbon core (2) with the adhesive strip at the end of the ribbon.
2. Insert the ribbon hub (3) into empty ribbon core (2) and new ribbon (1).
3. Wind the ribbon around the empty ribbon core (2) for 2 to 3 circles.

4.2.2 Ribbon Supply Module

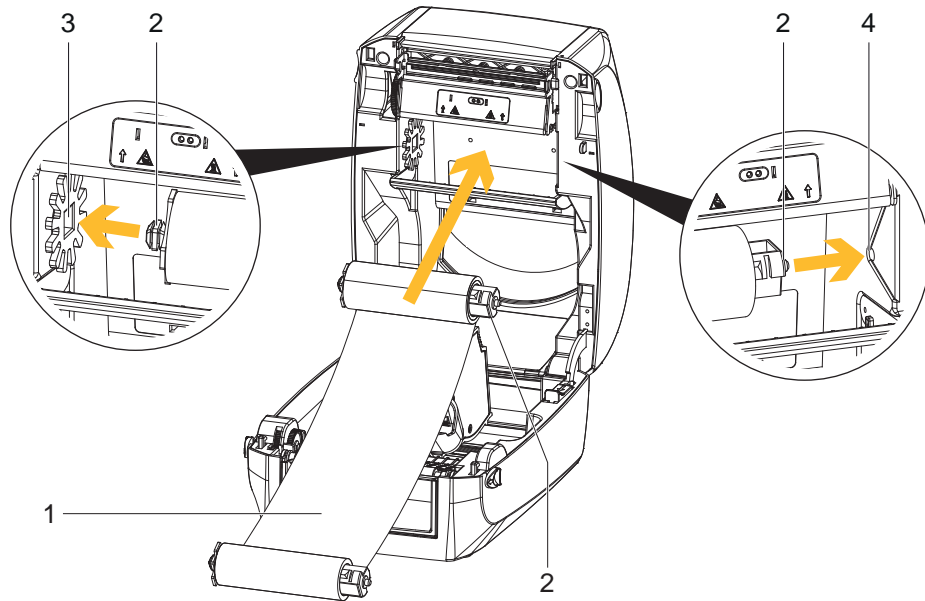

Fig. 12 Loading the ribbon module on the ribbon supply wheel

1. Unroll about 30 cm of the ribbon (1) from the roll, and place it as shown in the illustration.
2. Insert the ribbon hub and the ribbon roll (2) into the left side (3) of the ribbon supply module. Ensure that the stud on the ribbon hub slots into the recess.
3. Insert the ribbon hub with the ribbon roll (2) into the right side (4) of the ribbon supply module. Ensure that the stud on the ribbon hub slots into the recess.

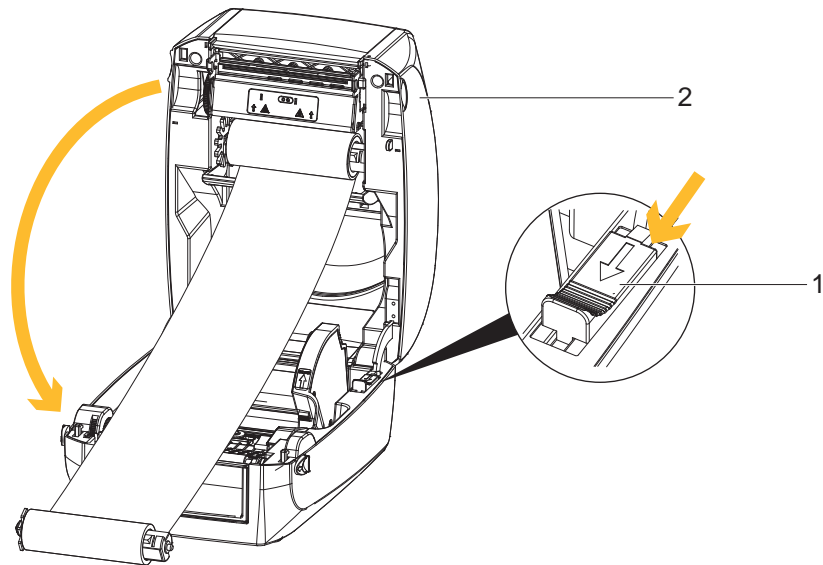

Fig. 13 Close the Printer Cover

4. Unlock the release catch (1) to close the printer cover.
5. Close the cover of the casing (2), and let it click shut.

4.2.3 Ribbon Rewind Module

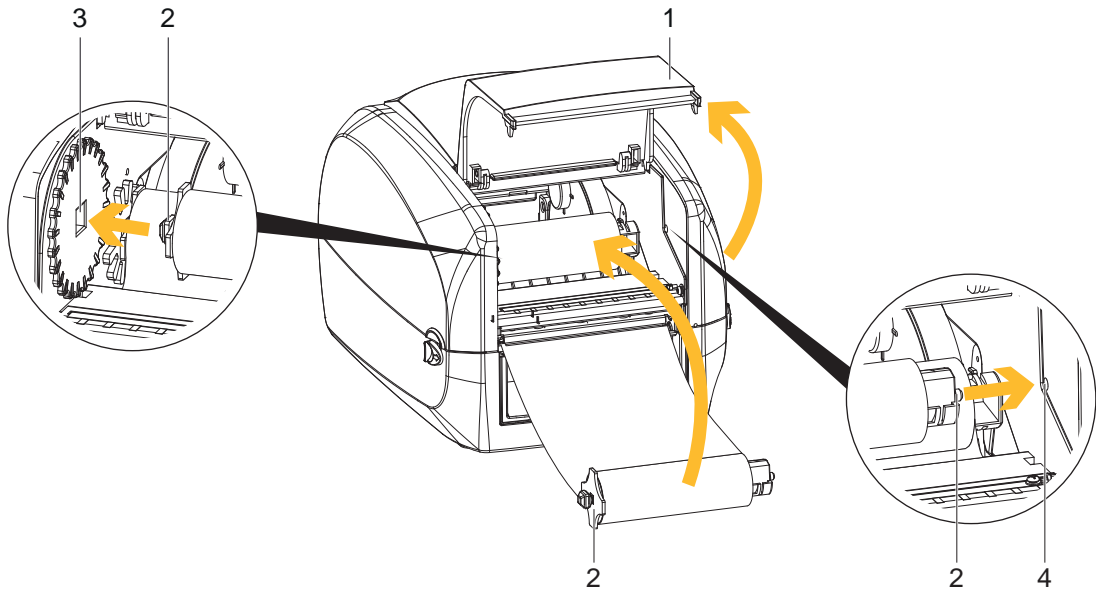

Fig. 14 Loading the ribbon module on the ribbon rewind wheel

1. Open the cover for Ribbon rewind mechanism (1).
2. Insert the ribbon hub with the ribbon core (2) into the left side (3) of the ribbon rewind module. Ensure that the stud on the ribbon hub slots into the recess.
3. Insert the ribbon hub with the ribbon core (2) into the right side (4) of the ribbon rewind module. Ensure that the stud on the ribbon hub slots into the recess.

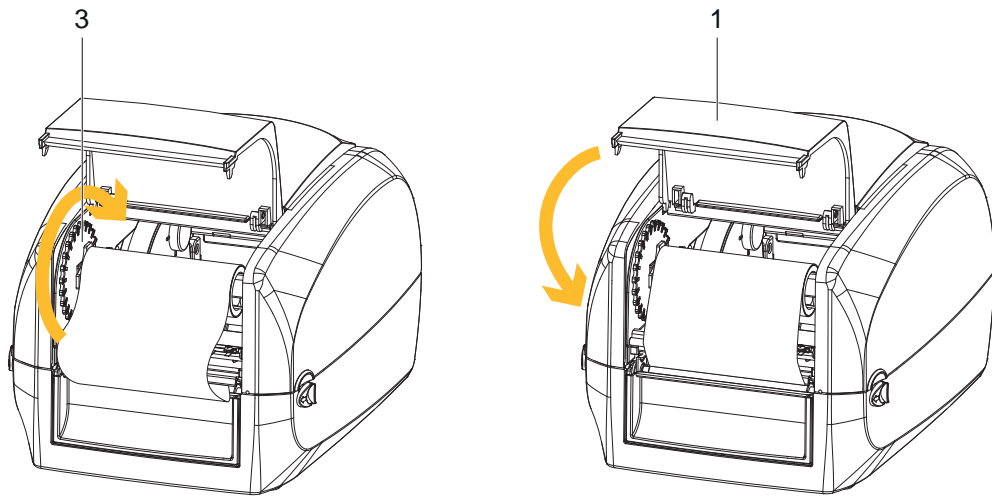

Fig. 15 Tighten the ribbon and close the printer

4. Turn the ribbon rewind wheel (3) to tighten the ribbon until it has no wrinkles.
5. Close the cover for Ribbon rewind mechanism (1).

4.3 Loading / Replacing the Label Stock on the Printer

1. Open the printer ▷ 4.1 on page 12.

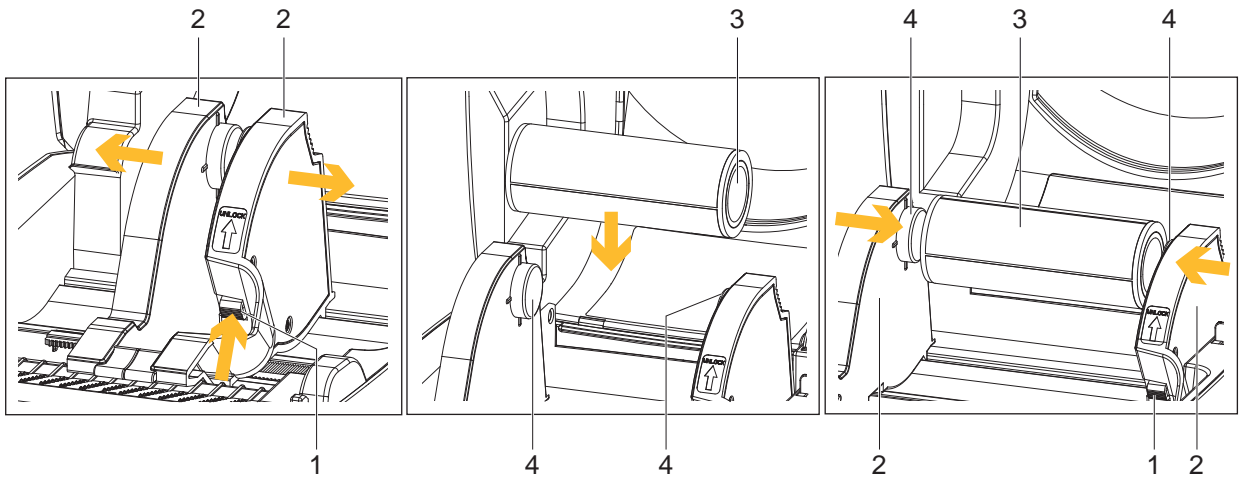

Fig. 16 Loading the label stock



Note!

The side label guide plates (2) can be shifted as long as the locking button (1) remains pressed.

2. Press the release catch for opening the label supply hub (1).
3. Pull to open the label guide plates (2).
4. Place the label stock (3) on label supply hubs (4). Make sure the label stock is aligned to both hubs.
5. Adjust the label guide plates (2) to fix the label width.
6. Release the locking button (1) and let it click into place.

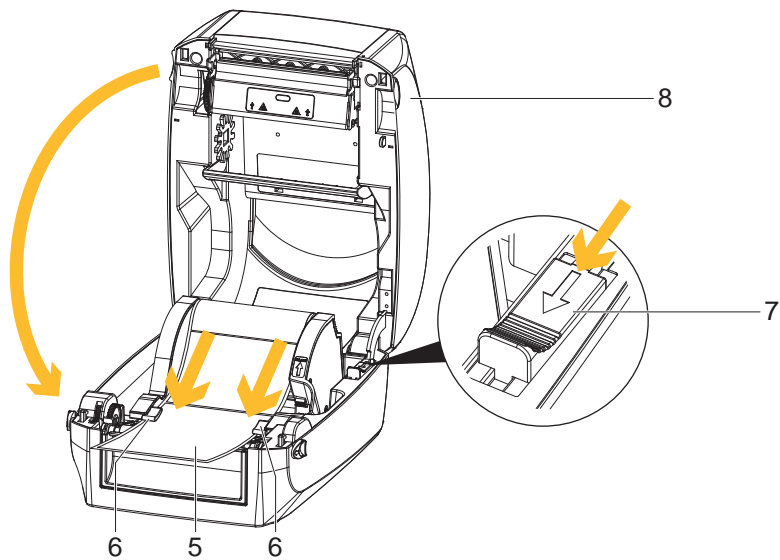

Fig. 17 Feed the label through the label guides and close the printer

7. Feed the Label (5) through the label guides (6) on both sides.
8. Unlock the release catch (7) to close the printer cover.
9. Close the cover of the casing (8), and let it click shut.

4.4 Function Test

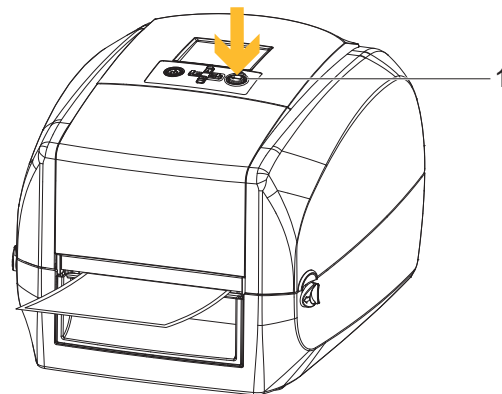

Fig. 18 Function Test

1. Connect the printer to the power supply.
2. Switch the printer on.
3. Press the FEED button (1).

If the label stock is inserted correctly, the labels are drawn in straight.

**Note!**

If the labels are drawn in skewed, check the seating of the ribbon and the label stock, and correct if necessary.

**Note!**

When Leporello labels (continuous material) are used the labels are drawn in by the feed on the back of the printer. It is not necessary to open the device.

5.1 Installing the Printer Driver



Note!

When the printer is connected via USB cable, the driver installation will be automatically made.

Insert the product DVD into the DVD drive of your computer, and enter this drive when you are prompted to enter a source for the driver during the installation.

1. Insert the Product DVD in the DVD drive of the host computer. The program should pop up automatically. You will see the Welcome screen first.
2. Choose "Drivers" on the Welcome screen.

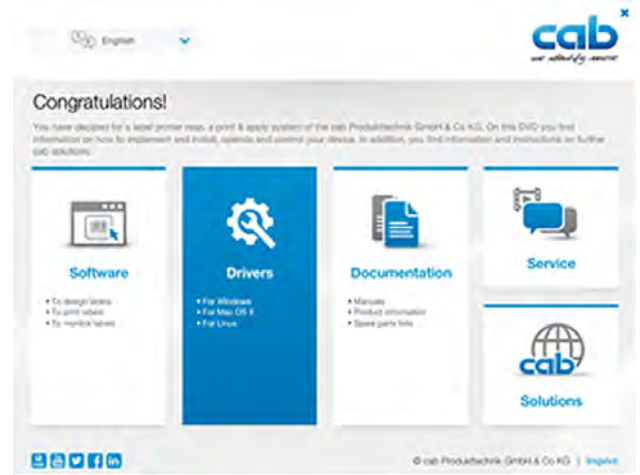

3. The "Drivers" screen appears. Click "Instal driver" to continue.

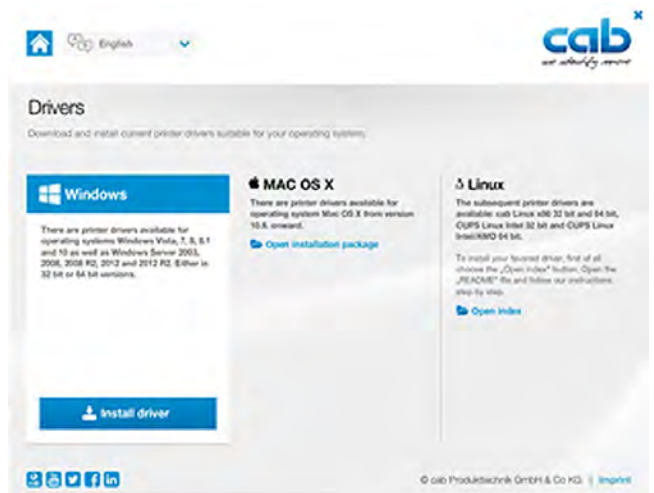

4. Follow the instructions on the screen. The Driver Wizard guides you through the installation procedure. Once the installation is complete, a summary of the printer settings is displayed. Check whether the printer settings are correct and click "Finish" to start copying the driver files.

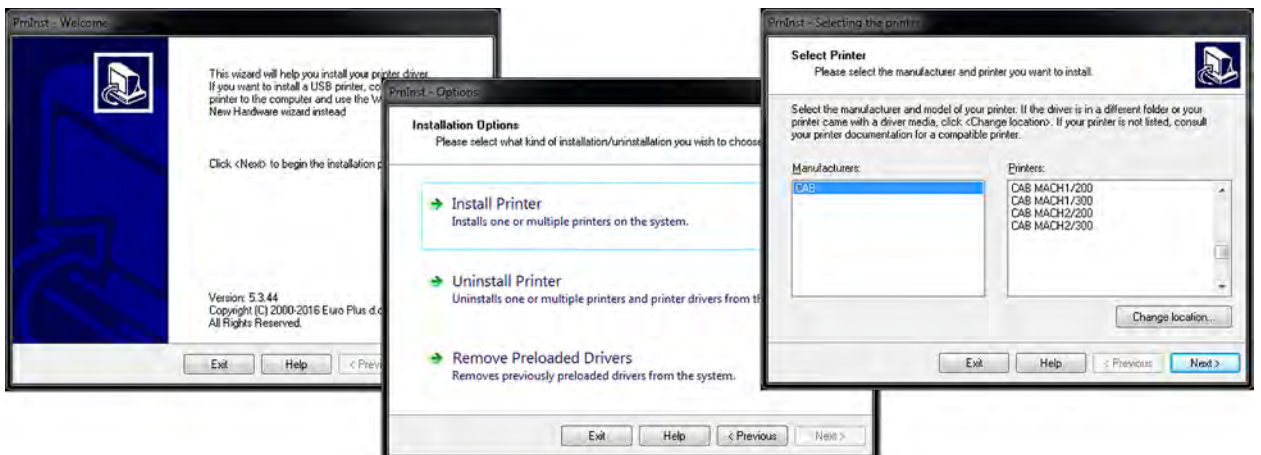

5.2 Installing Labeling Software cablabel S3 Lite

**Note!**

To create your labels, you can use the software cablabel S3 Lite. This label design software is included on the product CD and is free of charge.

You can obtain further software solutions with an extended range of functions (e.g. cablabel S3 Pro) from the manufacturer.

1. Insert the Product DVD in the DVD drive of the host computer. The program should pop up automatically. You will see the Welcome screen first.
2. Choose "Software" on the Welcome screen.
3. Select on the product CD the software **cablabel S3 Lite** and press the icon "Install software" to start the installation.

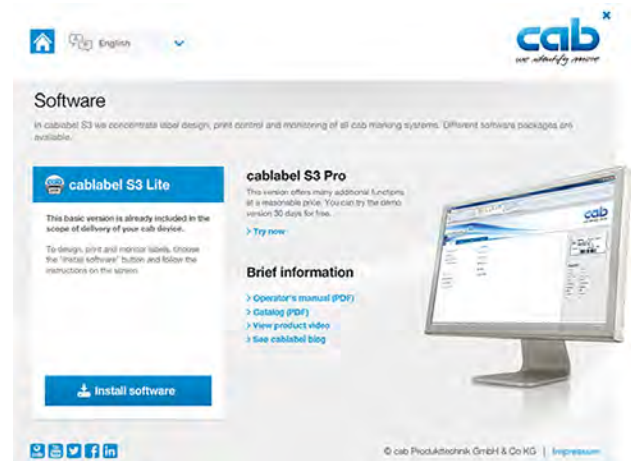

4. After the start of **cablabel S3 Lite** the MACH printer is available as a GDI device.

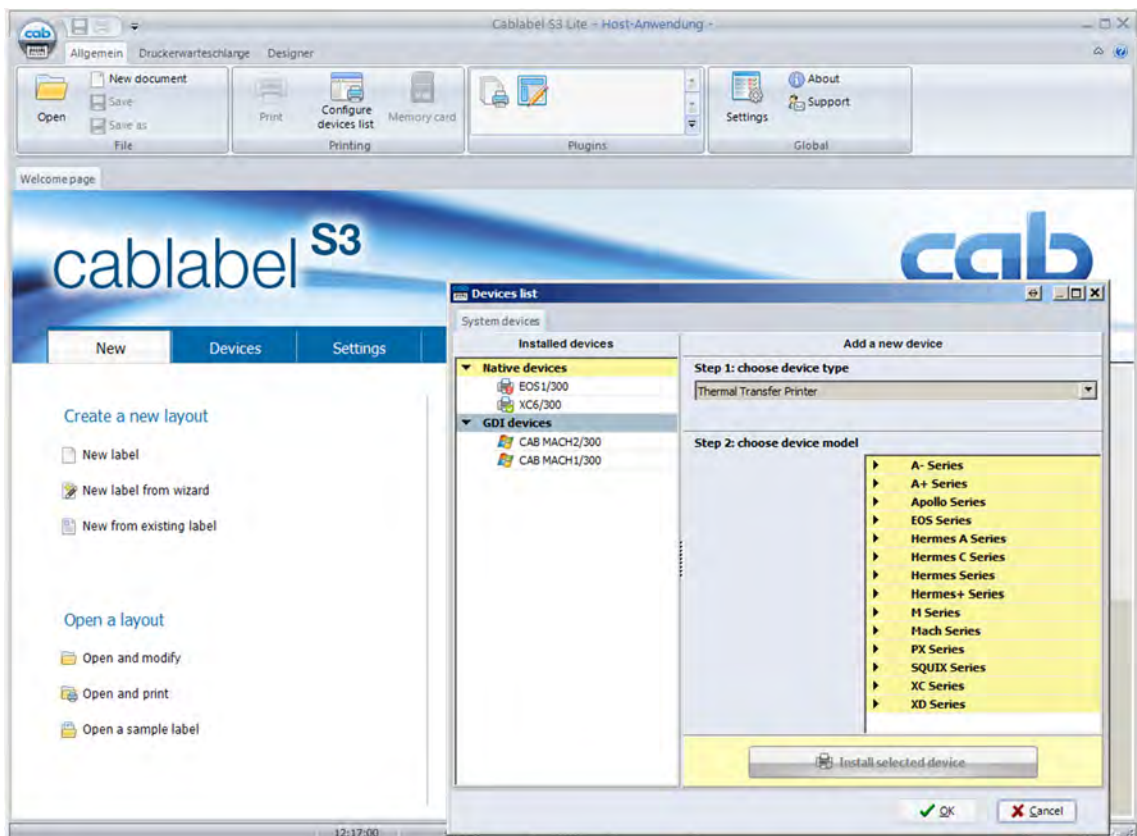

5.3 Configuration of Printer Settings

The Software Tool Mach1/2-Load



Note!
The software tool Mach1/2-Load is used to manage the printer settings and the configuration of the interfaces.

Starting the Tool Mach1/2-Load

- ▶ Insert the Product DVD in the DVD drive of the host computer.
- ▶ Start the Tool Mach1/2-Load by a double click



Printer Configuration

This tab allows you to configure and edit the settings of the connected printer.
Almost all important settings of the printer can be configured here.

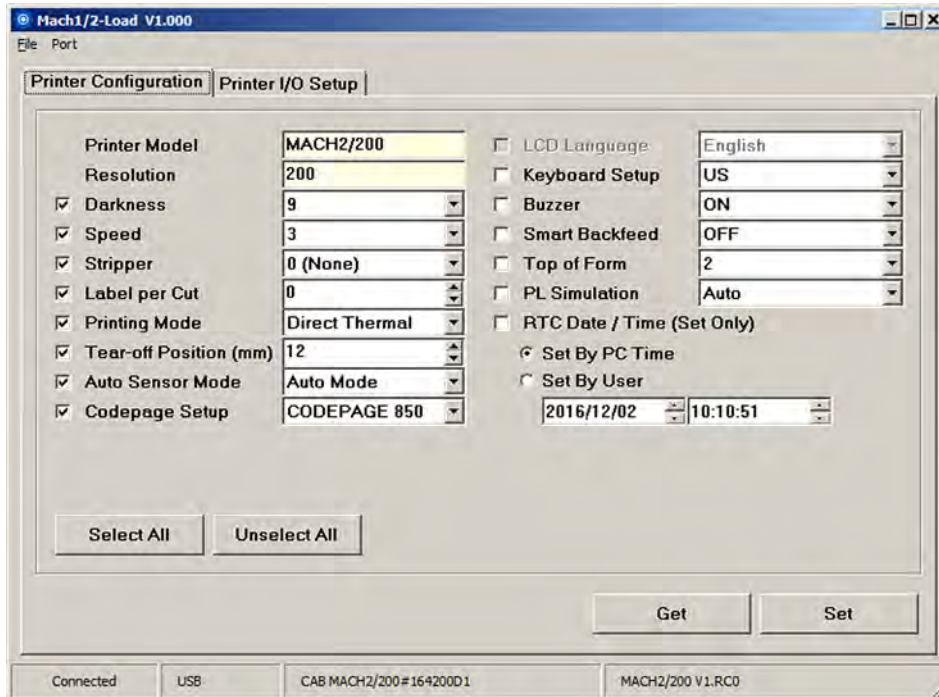

- ▶ Click "GET" to load the settings from the printer,
 - ▶ Click "SET" to send the settings to the printer. When you send only the selected parameters are transmitted.
- Under "File" you can save the settings in a configuration File, respectively load the settings from a file.

Printer I/O Setup

On this tab, you can make settings for the possible interfaces and send them to the printer.

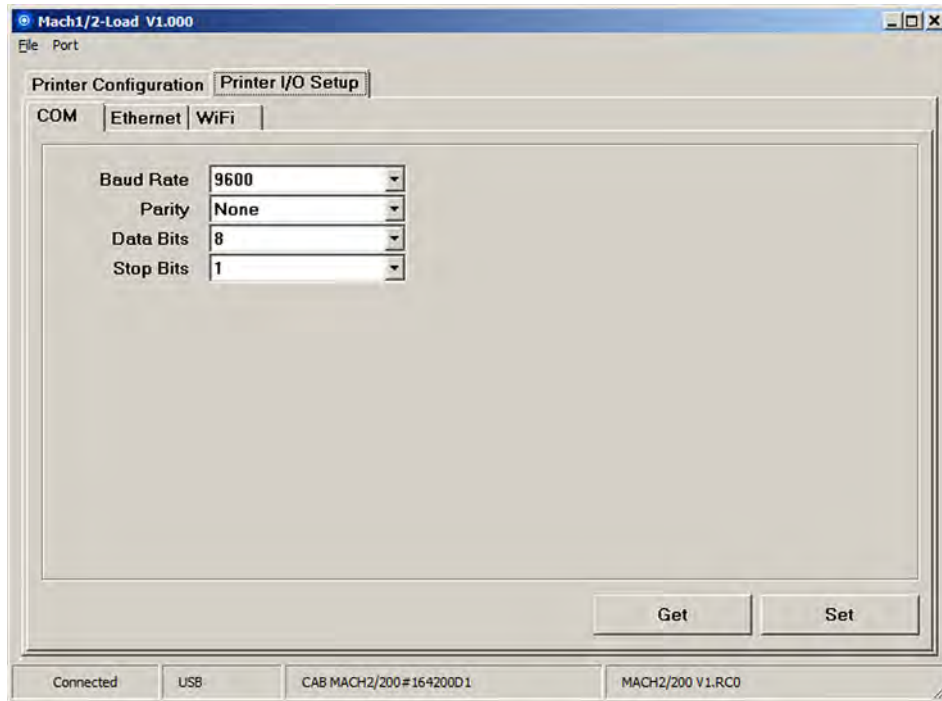

Port opens the "Port Setting". Here you have the possibility to search for all Mach1/2 models.

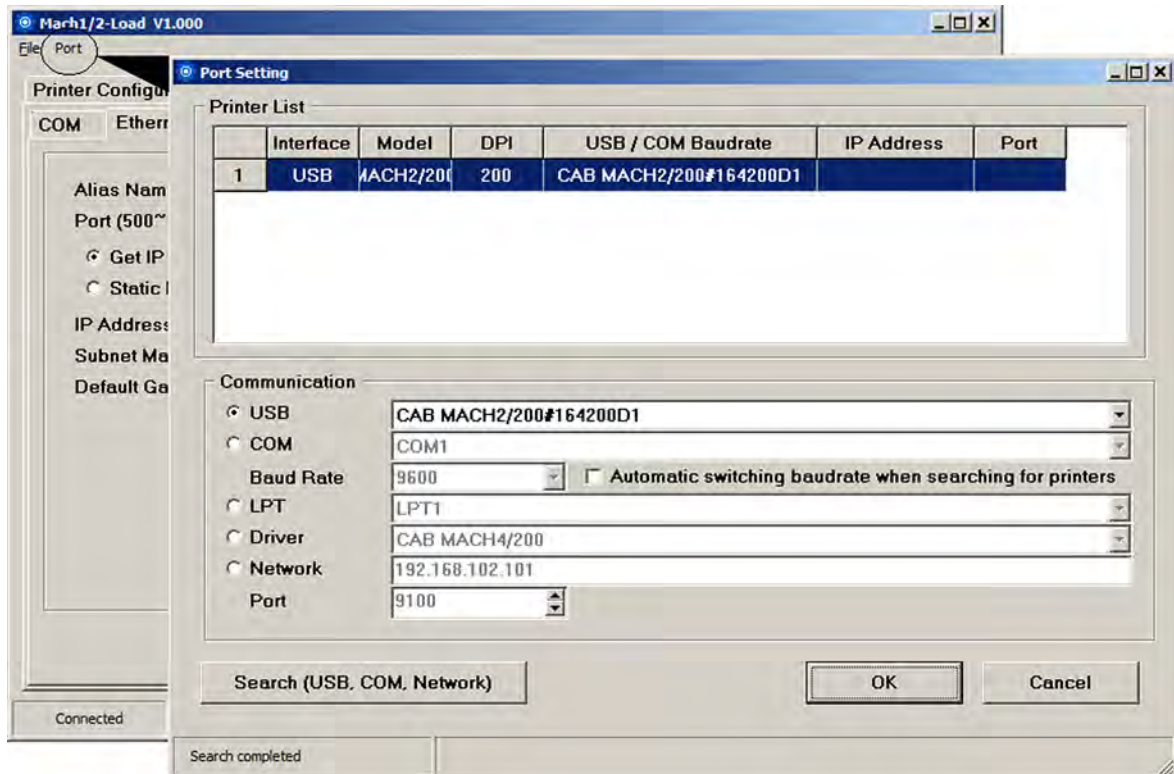

6.1 Operation Panel

Operation Panel Overview

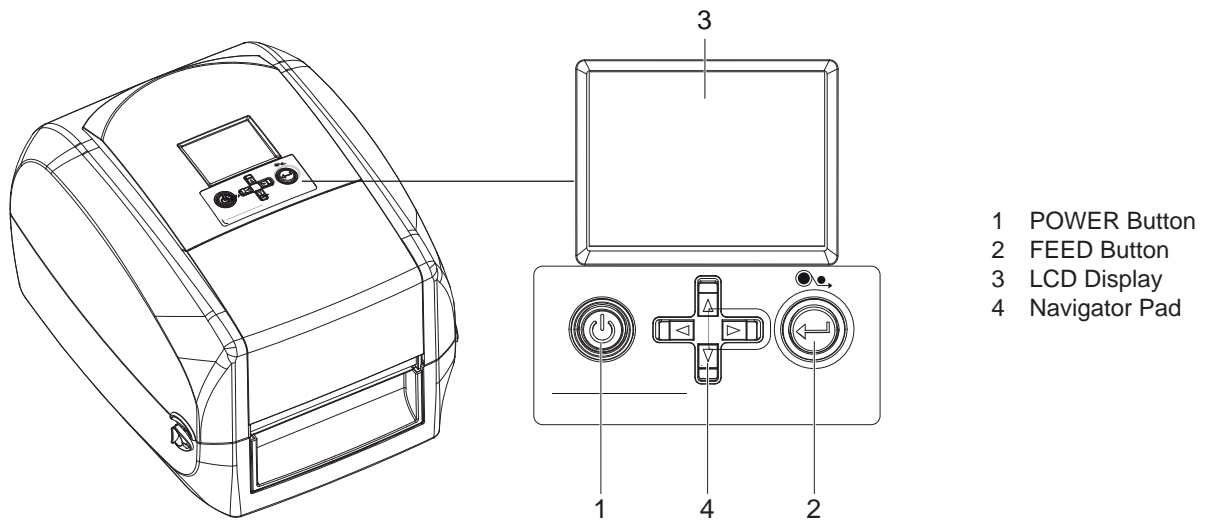

Fig. 19 Operation Panel Overview

POWER button

- ▶ Press the POWER button (1) to turn on the printer, and the START UP SCREEN appears. The printer is on “ready to print” status.
- ▶ The LCD screen (3) should display the message “READY” on the screen.
- ▶ When printer is turned on, keep pressing the POWER button (1) for 3 second will turn the printer off.

FEED button

When you press the FEED button, the printer moves the label to the defined stop position.

If you are using continuous labels, pressing the FEED button will move label stock until you release the button again.

If you are using individual labels, pressing the FEED button will move only one label.

**Note!**

If the label does not stop at the correct position, you need to run the auto-detection function on the label stock. ▶ 6.6 on page 35.

6.2 LCD Interface – Introduction

Status of LCD Interface

When printer is on standby status (ready to print), the LCD interface will display “Ready” on screen. You can only print on this “Ready” status.



If there is any printers error, the LCD screen will display the error screen to show the type of error. You can fix the error according the notice.

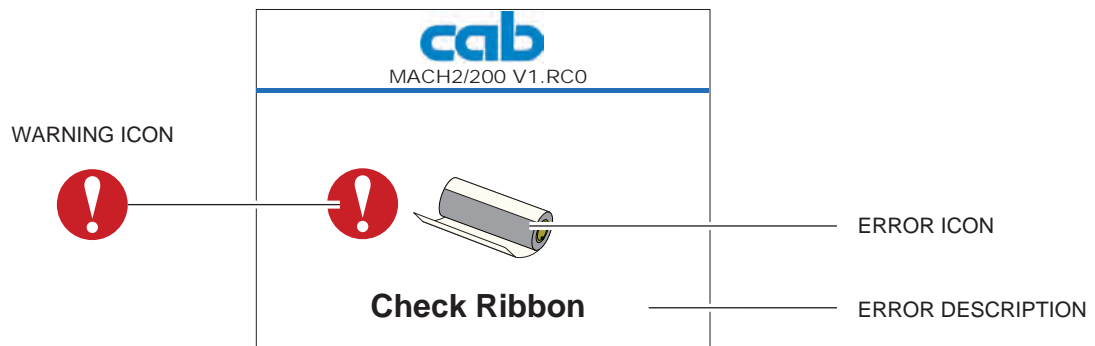

Icon Definition





	To upper level	Appears on the Navigation Icon of SettingPages. It guides you back to upper level bypressing “LEFT” key.
	To upper level	Appears on the Navigation Icon of SettingValue Pages. It guides you back to upper levelby pressing “UP” key.
	Lock	On Setting Value pages, press “RIGTH” key to lock the value for preventing unexpected change.
	Unlock	For locked value, press “RIGHT” key again toutlock the value.
	Scroll the value	On Setting Value pages, press “UP” or “DOWN” key to scroll the values for your selection.

Table 1 Icon Definition LCD Interface

Getting Started

Press the POWER button to turn on the printer, and the START UP SCREEN appears.



If the printer is on “ready to print” status, the LCD screen should display the message “Ready” on the screen.

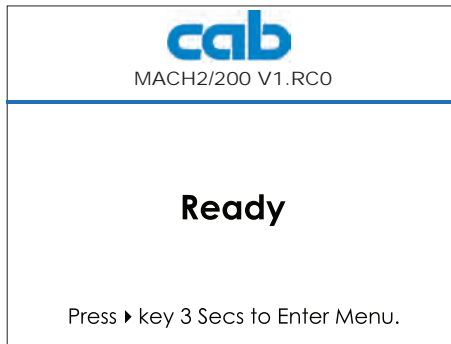

Please keep pressing ▶ button and wait for the timer to be filled, then the LCD interface will enter into the MAIN PAGE for SETTING MODE. You can make various setting functions in SETTING MODE.

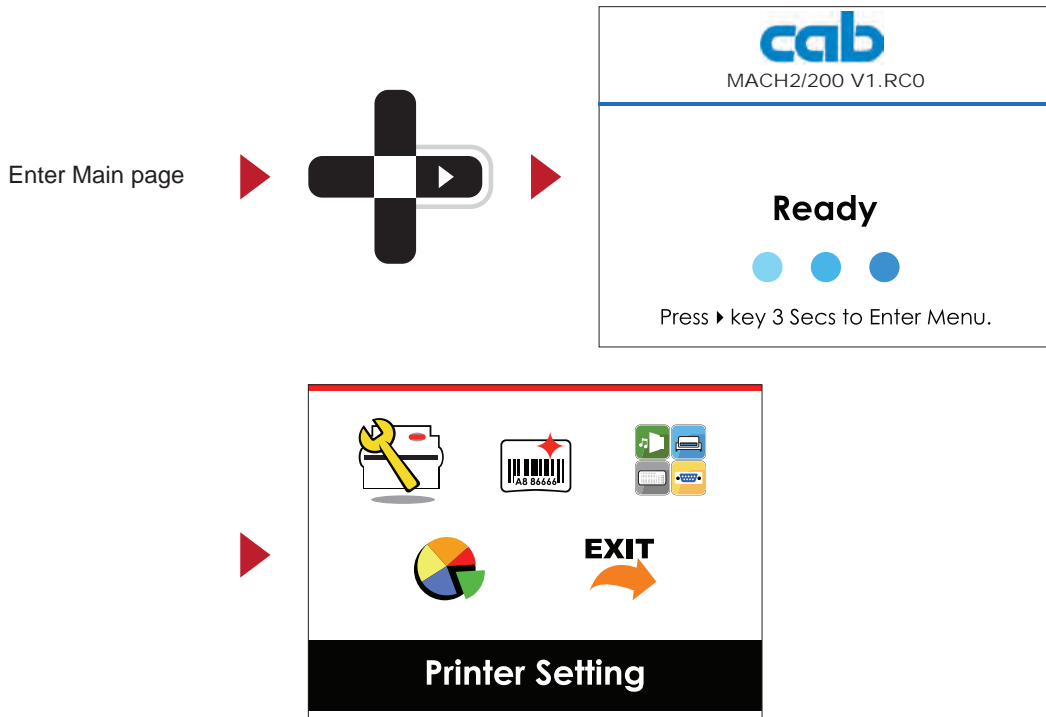

Operations on Setting Page

On MAIN PAGE, press ► or ◀ button to move the cursor and select the functions.

Select a designated function and press FEED button, you will enter the SETTING PAGES for the function.

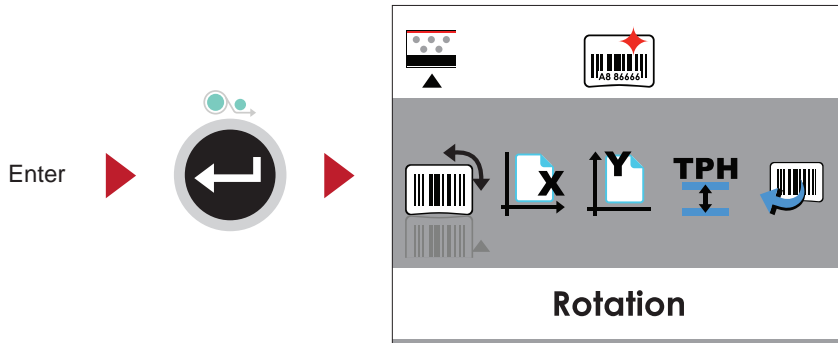
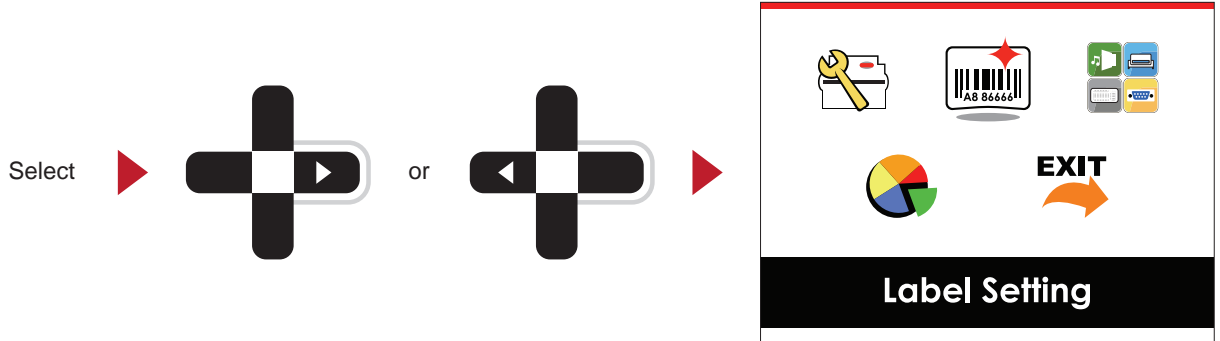

On SETTING PAGES, press ► or ◀ button to select the setting items.

Select a designated function and press FEED button, you will enter the SETTING VALUE PAGES for the function.

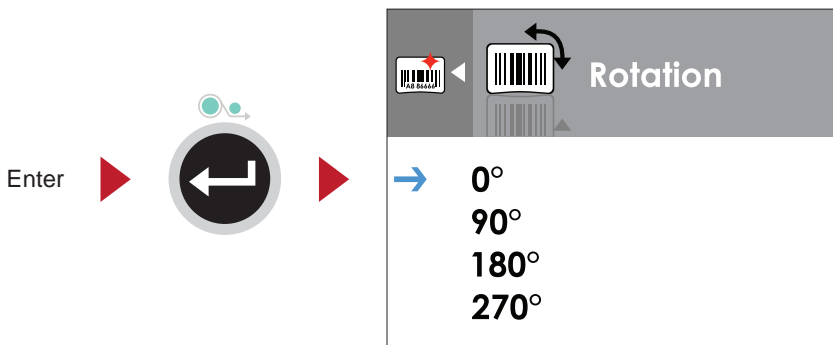
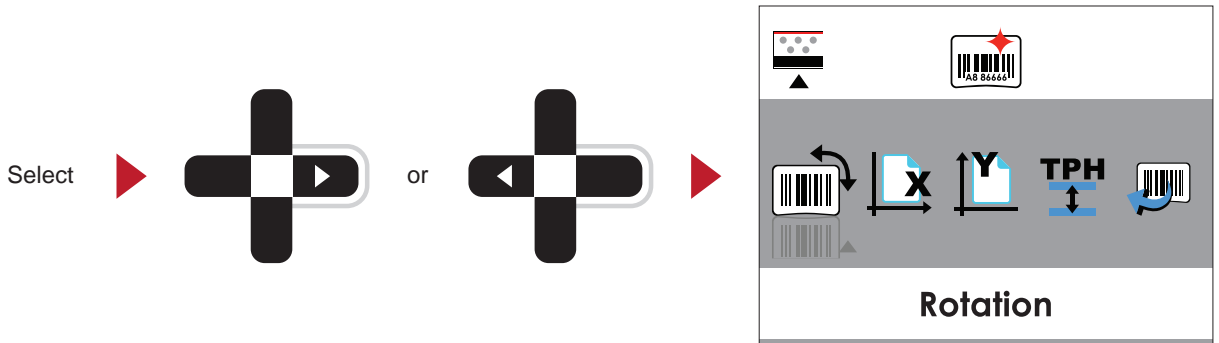

6 Printer Setting and Control

On SETTING VALUE PAGES, press ▲ or ▼ dbutton to change the setting values.

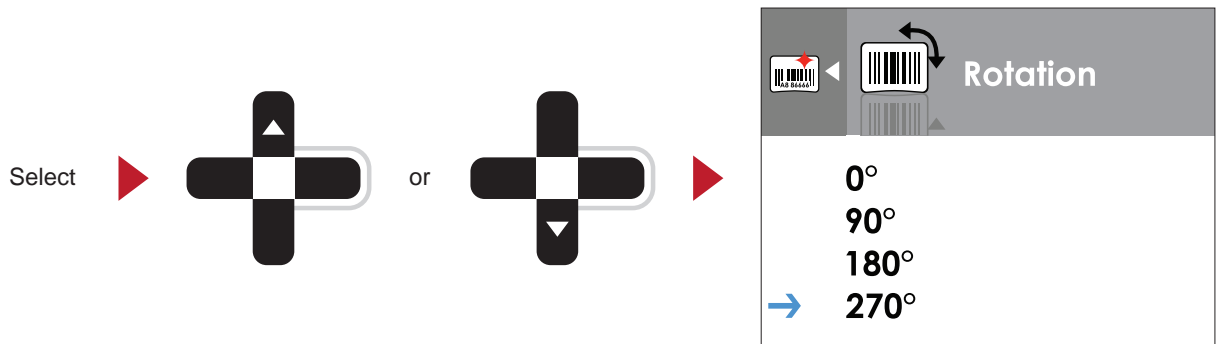

Press FEED button will apply the setting value you just selected, and the red tick will appear to mark the value.

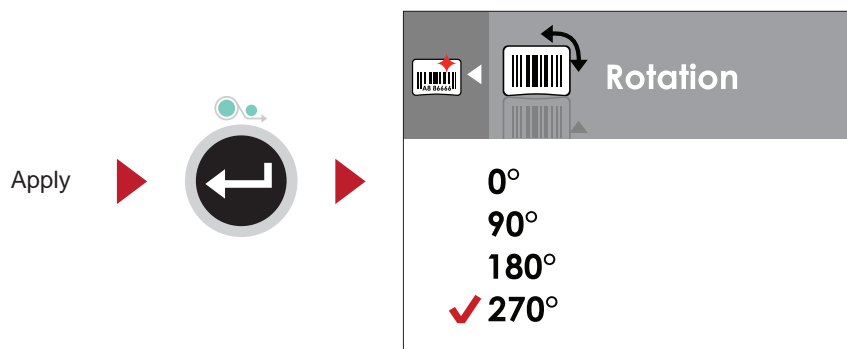

Note!
The blue arrow indicates the value you are selected.



The red tick indicates that the selected value is applied now.



Exit from Current Page to Ready Status

The icon on top-left corner displays the capture of upper level screen and also guides you back to upper level with left or up arrow.

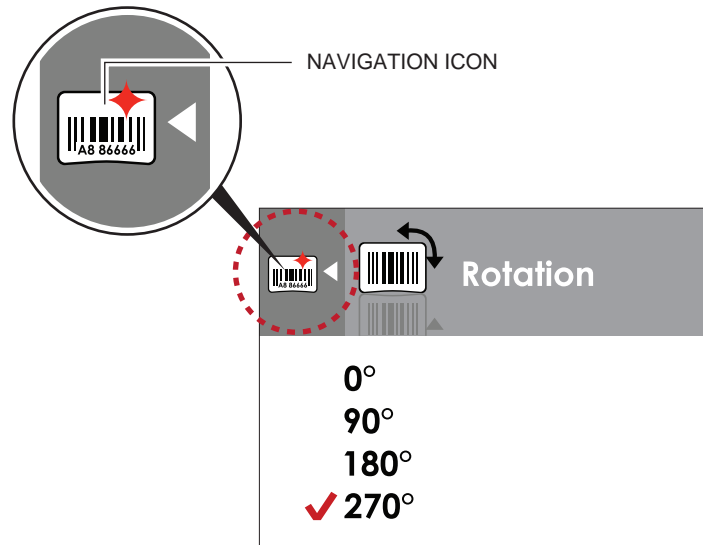

On SETTING VALUE PAGES, press ◀ button will go back to the upper level screen.

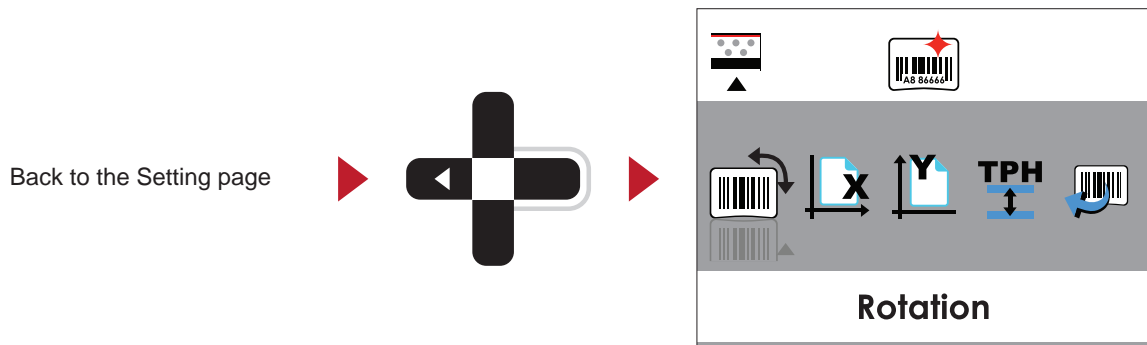

On SETTING PAGES, press ▲ button will go back to the MAIN PAGE screen.

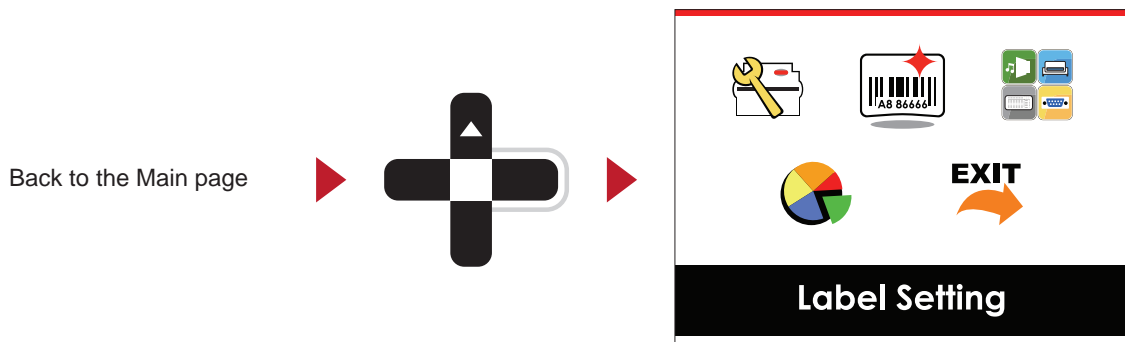

6 Printer Setting and Control

On MAIN PAGE select Symbol EXIT and press the FEED button.
The printer now displays again the status "Ready".

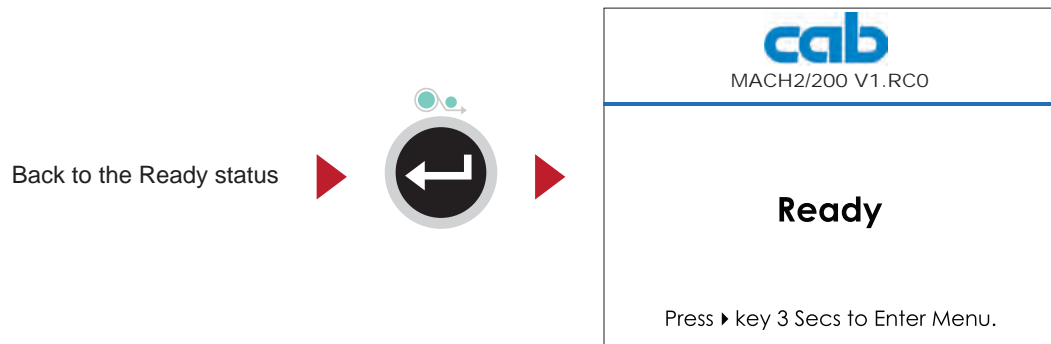
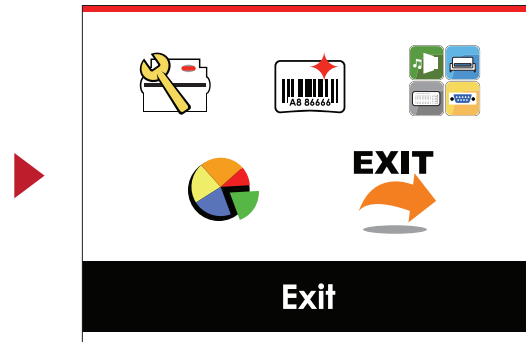
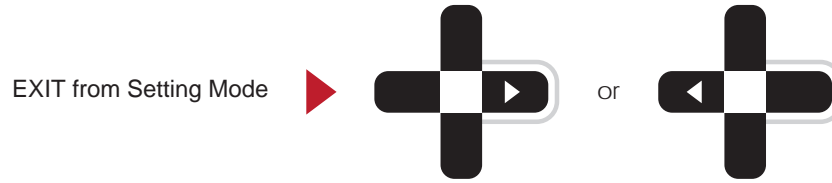

6.3 Ethernet Setting

Operations on Setting Page

On MAIN PAGE press ► or ◀ button to move the cursor and select the functions.

Select a designated function and press FEED button, you will enter the SETTING PAGES for the function.

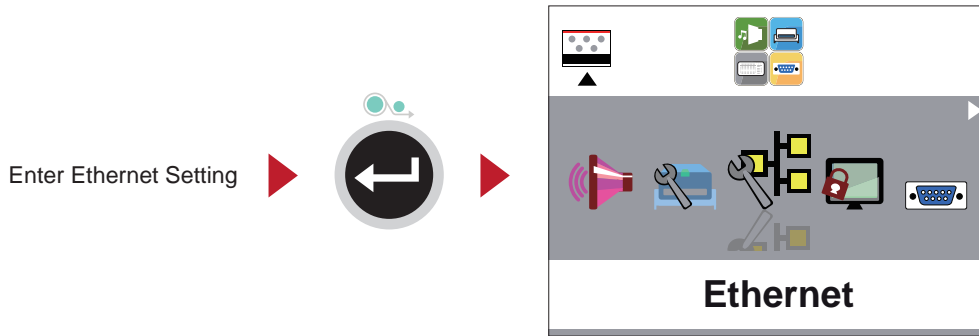
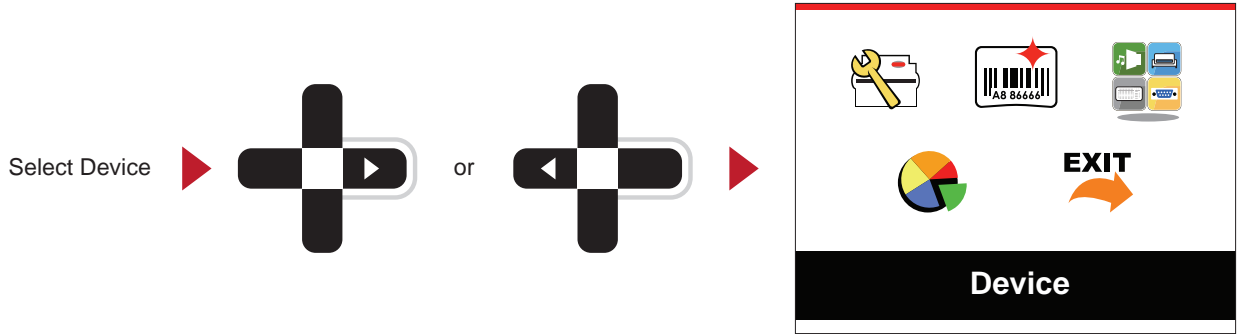

On Ethernet Setting PAGE press ► or ◀ button to select the setting items.

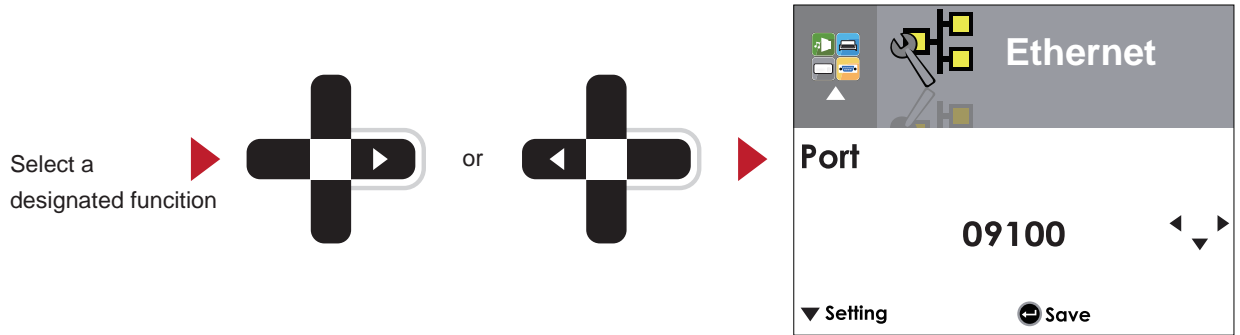

Select DHCP and press FEED button, you will be able to setup DHCP function.

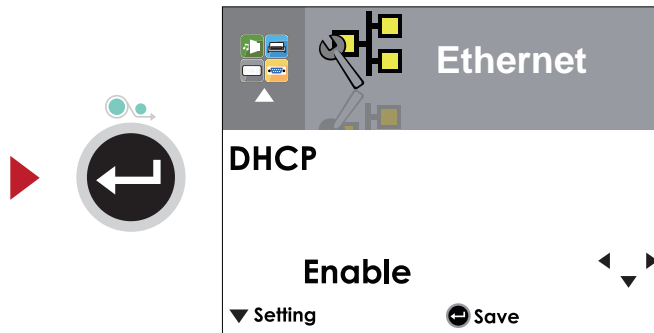

The default of DHCP is Disable. Press ▲ or ▼ button to change the setting values.

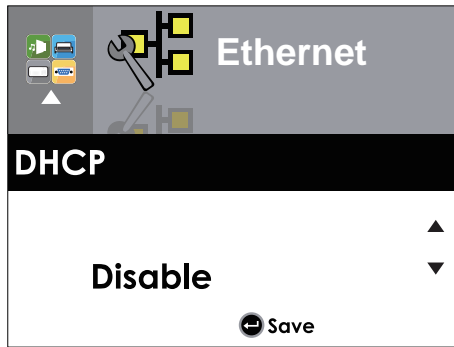

Select ▼ to enable DHCP

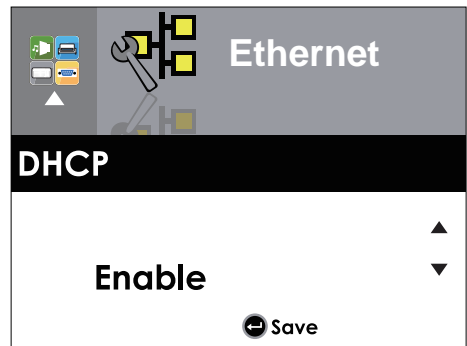
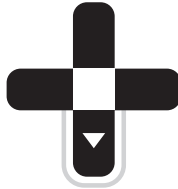

Press FEED button twice to save the setting.

Press FEED once to exit.

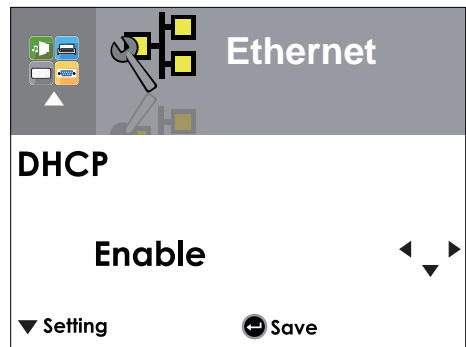

Press FEED again to save and return to previous SETTING PAGE.

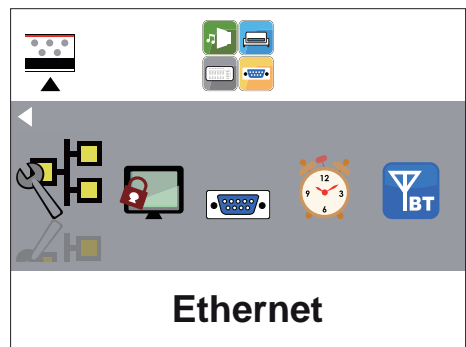

6.4 LCD Password

Operations on Setting Page

On MAIN PAGE, press ► or ◀ button to move the cursor and select the functions.

Select a designated function and press FEED button, you will enter the SETTING PAGE for the function.

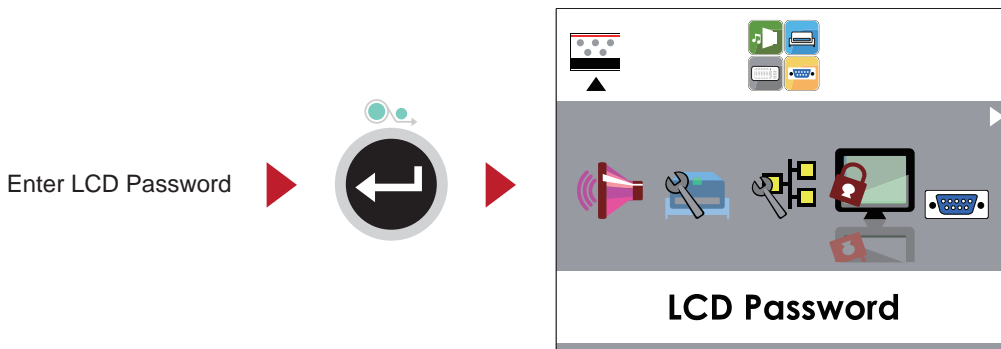
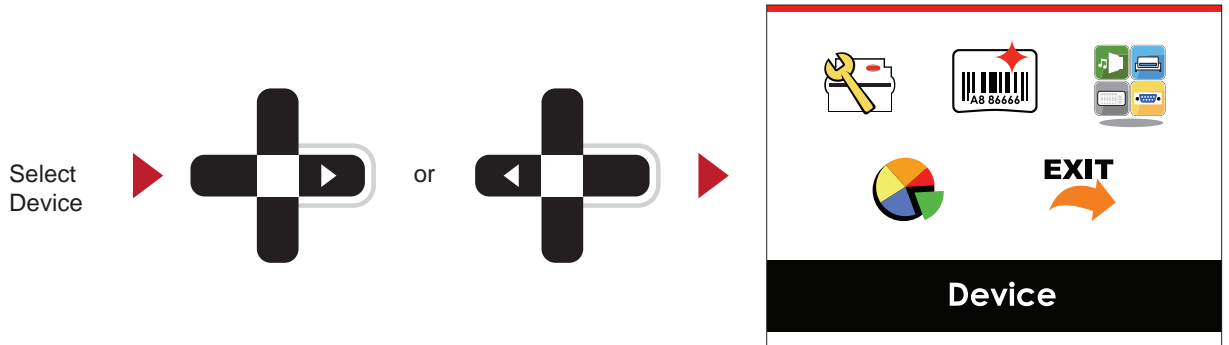

The default of LCD Setting is Disable.

Press ▲ or ▼ button to change the setting values.

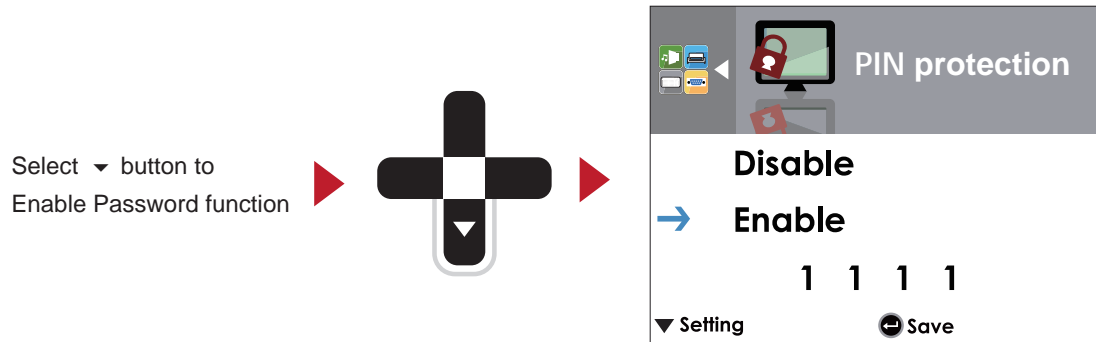

Select ▼ button again to setup the password

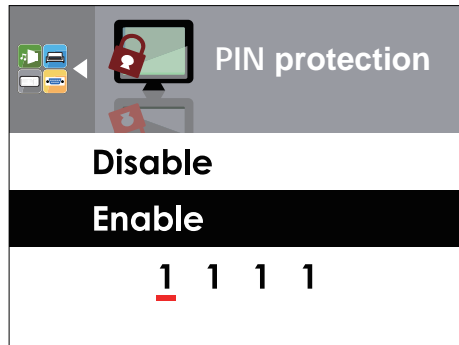
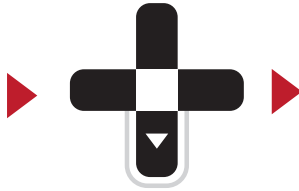

Press FEED button twice to save the setting.

Press FEED button once to exit.

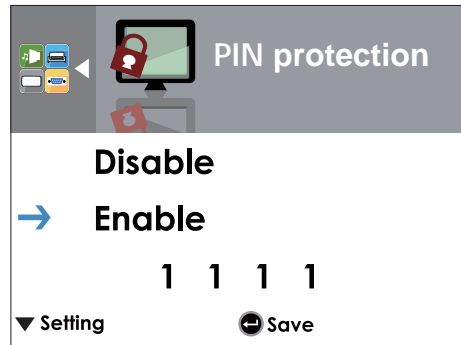

Press FEED button again to save and return to previous SETTING PAGE

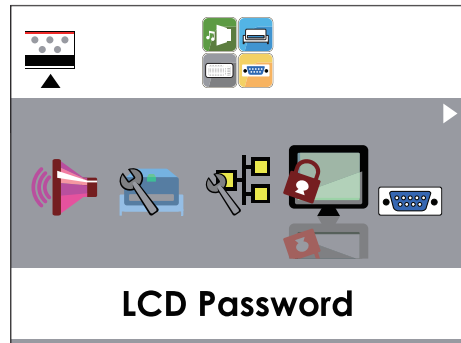

6.5 LCD Interface – Function

Main Page

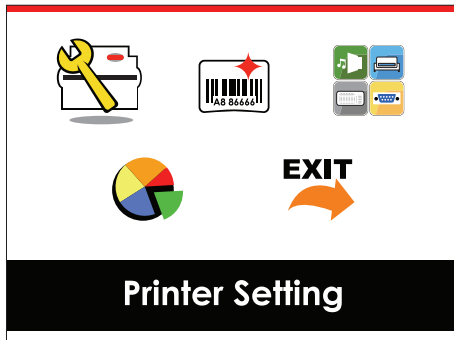

Setting items for printer, ex. Printing speed, heat level.
Also includes a Printing Wizard for your ease of printing.



Setting items for printing label, ex. Rotation, Printing position offset.



Option modules and connection port settings.



Self-Diagnose functions for printer, ex. TPH testing, self-test page printing.



Exit from Setting Mode.

Table 2 Symbols on Main Page

Setting Items in Setting Mode



Language		English	Español	
		Deutsch	日本語	
		繁體中文	Italiano	
		简体中文	Русский	
		Français	Türkçe	
Wizard	Print speed	2-5 or 7		
	Heat level	0-19		
	Media Type		Label with Gaps	
			Label with Marks	
			Continuous	
	Print Mode		Direct Thermal	
			Thermal Transfer	
Tear-off Position	0-40			
Setting	Heat level	0-19		
	Print speed	2-5		
	Label Sensor		Label Sensor	Auto Select
				Gap Sensor
				Reflect
	Media Type		Label with Gaps	Label with Marks
				Continuous
	Print Mode		Direct Thermal	Thermal Transfer
				Thermal Transfer
	Tear-off Position	0-40		
	Top of Form		Enter	
			Abbrechen	
	Character set		850	737
		852	851	
		437	869	
		860	Win 1252	
		863	Win 1250	
		865	Win 1251	
		857	Win 1253	
		861	Win 1254	
		862	Win 1255	
		855	Win 1257	
	866			



Rotation		0°
		90°
		180°
		270°
	Printhead pos.X	-100 – 100
Printhead pos.Y	-100 – 100	
Start Offset	-100 – 100	
Load Label		001 Form Name
		002 Form Name



Device

	Key tone	Enter	Abbrechen	
Device Setting	Options	None	Present Sensor	
		Cutter	Applicator	
	Smart Backfeed	Apply	Cancel	
Ethernet	Part.	09100		
	DHCP	Disable	Enable	
	Gateway	192.168.000.254		
	Dynamic IP	192.168.102.76		
	Netmask	255.255.255.0		
LCD Password		Disable	Enable	
	Baud Rate	4800 bps	38400 bps	
9600 bps		57600 bps		
19200 bps		115200 bps		
RS 232 Setting	Parity	None	Odd	
			Even	
	Data Bits	7 Bit	8 Bit	
Stop Bits	1 Bit	2 Bit		
Date-Time	Clock Display	Apply	Cancel	
	Dat-Time Setting	JJJJ/MM/TT	HH:MM:SS	
Diagnostics	Calibration	Apply	Cancel	
	Test print		Apply	
		Label Format	Apply	Cancel
	Clear Memory	Images	Apply	Cancel
		Bitmap Fonts	Apply	Cancel
		True Type Fonts	Apply	Cancel
		Asian Fonts	Apply	Cancel
		ALL	Apply	Cancel
	Printhead Test	Apply	Cancel	
	Restore Default	Apply	Cancel	
	Exit			



Exit

Table 3 Setting Items in Setting Mode

6.6 Label Calibration and Self Test

Label Calibration

The printer can automatically detect and store label height. That means the host computer does not need to transmit the label height to the printer.

Self Test

Self-test function lets you check whether the printer is functioning normally. Here is how you run the label size calibration and self test.

1. Check that the label stock is loaded correctly.
2. Turn off the printer.
3. Turn the printer on again, keeping the FEED button pressed. When the LCD display shows "Ready", release the FEED button. The printer will now measure the label stock and store the label height.
4. Once the printer has successfully measured the label stock, it will print a self-test label.

The contents of a self-test printout are listed below.

Modell & Version	MACH1/200:GX.XXX
USB ID setting	USB S/N:12345678
Serial port setting	Serial port:96,N,8,1
MAC address of Ethernet port	MAC Addr:xx-xx-xx-xx-xx-xx
IP protocol setting	DHCP Enable
IP address of Ethernet port	IP xxx.xxx.xxx.xxx
Gateway setting	Gateway xxx.xxx.xxx.xxx
Netmask setting	Sub-Mask xxx.xxx.xxx.xxx
	#####
Number of DRAM installed	1 DRAM installed
Image buffer size	Image buffer size:1500 KB
Number of forms	0000 FORM(S) IN MEMORY
Number of graphics	0000 GRAPHIC(S) IN MEMORY
Number of fonts	000 FONT(S) IN MEMORY
Number of Asian fonts	000 ASIAN FONT(S) IN MEMORY
Number of Databases	000 DATABASE(S) IN MEMORY
Number of Scalable fonts	000 TTF(S) IN MEMORY
Free memory size	4073 KB FREE MEMORY
Speed, Density, Ref. Point, Print direction	^S4 ^H8 ^R000 ~R200
Label width, Form length, Stop position	^W102 ^Q100,3 ^E18
Cutter, Label Dispenser, Mode	Option:^D0 ^O0 ^AD
Sensor Setting	Reflective AD:1.96 2.84 2.49[0.88_23]
Code Page	Code Page:850
Printer is on factory default	Default state=Yes

Label Calibration Button

**Note!**

A hardware button to make a Label Calibration while printer encountering “Media Error” during the cases when first-time printer start up or change label or ribbon to another type, such as change using gap label to continuous or black mark labels.

Press C-button for 2 seconds, it will make an auto-sensing to calibrate the label and ribbon’s parameters.

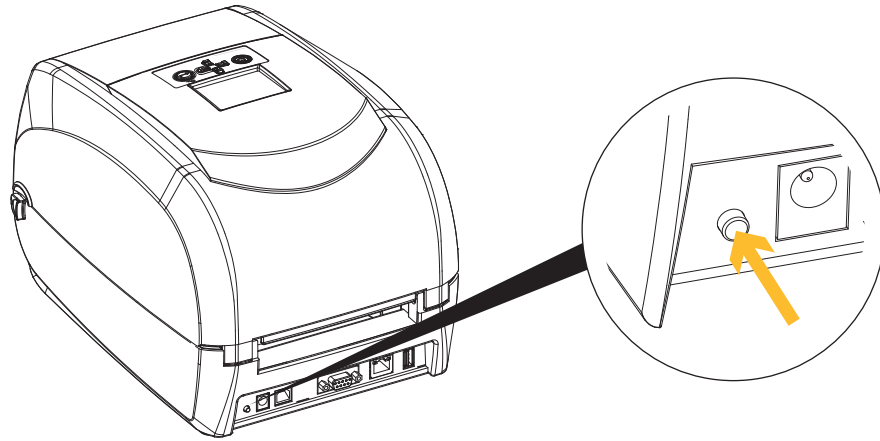

Fig. 20 Label Calibration Button

**Note!**

The printer does not require any maintenance.

Apart from consumables (ribbon / label stock), no mechanical components have to be set up or changed in order to operate the device.

7.1 Cleaning

7.1.1 General Cleaning Information

**Danger!**

Risk of death via electric shock!

► Disconnect the printer from the power supply before performing any maintenance work.

The printer requires very little maintenance.

It is important to clean the thermal printheads regularly. This guarantees a consistently good printed image and plays a major part in preventing premature wear of the printhead.

Otherwise, the maintenance is limited to monthly cleaning of the device.

**Attention!**

The printer can be damaged by aggressive cleansers.

► Do not use abrasive cleaners or solvents for cleaning the external surfaces or modules.

1. Remove dust and paper fluff from the print area with a soft brush or vacuum cleaner.
2. The cover of the printer can be cleaned with a standard cleanser.

7.1.2 Cleaning the Print Head

Dirt on the print head or ribbon, or glue residue from the label stock may result in inadequate print quality. The printer cover must therefore always be closed during printing. Keeping dirt and dust away from the paper or labels ensures a good print quality and a longer lifespan of the print head.

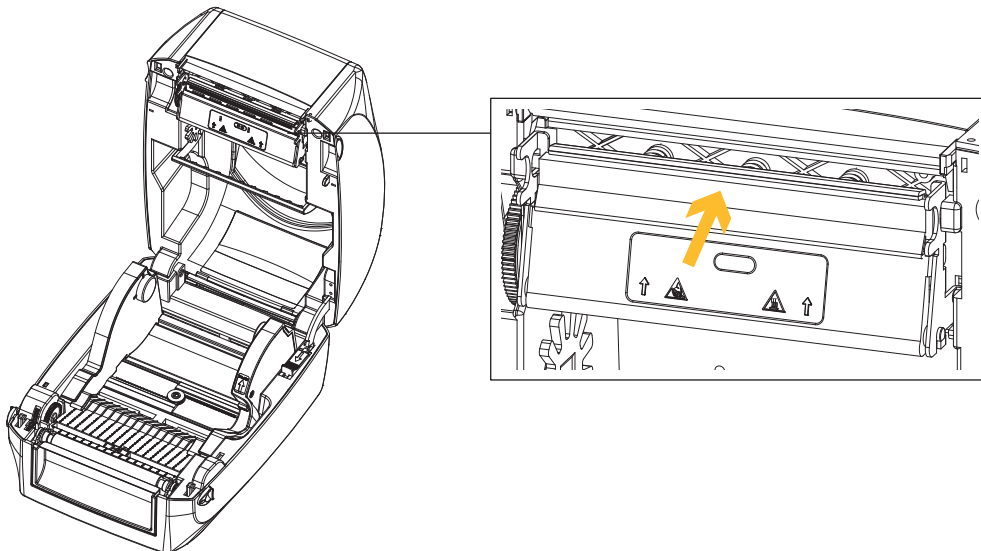

Fig. 21 Cleaning the Print Head

**Attention!**

Printheads can be damaged!

- Do not use sharp or hard objects to clean the printheads.
- Do not touch protective glass layer of the printheads with fingers.



Attention!

Risk of injury from the hot printhead lines.

- ▶ Ensure that the printheads have cooled down before starting cleaning.

Cleaning Steps

1. Turn off the printer.
2. Open the printer cover.
3. Remove the ribbon.
4. To remove any label residue or other dirt from the print head (see arrow), please use a soft lint-free cloth dipped in alcohol.

7.2 Error Alerts

In the event of a problem that prevents normal functioning of the printer, you will see an error message on LCD screen and hear some beep signals.

Status	Type	Beeps	Description	Solution
 Printhead up (Open)	Print Head Error	2 x 4 beeps	The printing mechanism is not correctly closed.	Open the print mechanism and close it again.
 TPH overheat	Print Head Error	None	High temperature at the print head.	Once the print head has cooled down, the printer switches to standby mode.
 Check Ribbon	Media Error	2 x 3 beeps	No ribbon is installed and the printer displays an error. The ribbon is finished or the label supply hub is not moving.	Vergewissern Sie sich, dass der Druckmodus "Thermodirektdruck" eingestellt ist. Replace the ribbon roll.
 Check Media	Media Error	2 x 2 beeps	No paper is detected. Paper is finished. Printer feed problem.	Make sure that the label sensor is positioned correctly. If the sensor still does not detect the paper, run the auto-detection function again. Replace the label roll. Possible reasons: the print medium has become trapped around the rubber roll; the sensor cannot detect a gap or black mark between the labels; there is no paper. Please reset the sensor.
 Memory full	File Error	2 x 2 beeps	The memory is full. The printer prints the message "File System full".	Delete unnecessary data or install additional memory.
 File name can't be found			Unable to find file. The printer prints the message "File Name not found".	Use the "~X4" command to print all files. Then check whether the files exist and whether the names are correct.



   File name duplicated	File Error	2 x 2 beeps	A file of the same name already exists. The printer prints the message "Duplicate Name".	Change the name of the file and try storing it again.
--	------------	-------------	--	---

Table 4 Error Alerts

7.3 Troubleshooting

Problem	Lösung
The label stock passes through the printer but no image is printed.	<ul style="list-style-type: none"> ▶ Please make sure that the label stock is loaded the right way up and that it is suitable material. ▶ Choose the correct printer driver. ▶ Choose the correct label stock and a suitable printing mode.
The label stock jams during printing.	<ul style="list-style-type: none"> ▶ Clear the paper jam. Remove any label material left on the thermal print head and clean the print head using a soft lint-free cloth dipped in alcohol. ▷ 7.1.2 on page 37
There is no printed image on some parts of the label.	<ul style="list-style-type: none"> ▶ Check whether any label material or ribbon is stuck to the thermal print head. ▶ Check for errors in the application software. ▶ Check whether the starting position has been set correctly. ▶ Check the ribbon for wrinkles.
There is no printed image on part of the label or the image is blurred.	<ul style="list-style-type: none"> ▶ Check the thermal print head for dust or other dirt. ▶ Use the internal “~T” command to check whether the thermal print head will carry out a complete print job. ▶ Check the quality of the print medium.
The printed image is positioned incorrectly.	<ul style="list-style-type: none"> ▶ Check whether there is paper or dust covering the sensor. ▶ Check whether the label stock is suitable. Contact your supplier. ▶ Check the paper guide settings.
A label is missed out during printing.	<ul style="list-style-type: none"> ▶ Check the label height setting. ▶ Check whether there is dust covering the sensor. ▶ Run the auto-detection function. ▷ 6.6 on page 35
The printed image is blurred.	<ul style="list-style-type: none"> ▶ Check the darkness setting. ▶ Check the thermal print head for dust or dirt. ▷ 7.1.2 on page 37
The cutter * does not cut off the labels in a straight line.	<ul style="list-style-type: none"> ▶ Check whether the label stock is positioned straight.
The cutter * does not cut off the labels completely.	<ul style="list-style-type: none"> ▶ Check whether the label is more than 0.2 mm thick.
When using the cutter *, the labels are not fed through or cut off incorrectly.	<ul style="list-style-type: none"> ▶ Check whether the cutter has been correctly installed. ▶ Check whether the paper guides are functioning correctly.
The present sensor * is not functioning normally.	<ul style="list-style-type: none"> ▶ Check whether there is dust on the present sensor. ▶ Check whether the label stock is positioned correctly.

Table 5 Troubleshooting



Note!

If any problems occur that are not described here, please contact your dealer.

8.1 Preparation Steps

**Note!**

The accessories, Present Sensor and cutter, can only be installed separately. They cannot be combined.

Open the Printer

Fig. 22 Open the printer

- ▶ Place the printer on a flat surface.
- ▶ Pull the cover release catches (1) on both sides of the printer.
- ▶ Raise the cover of the casing (2) and lock it into the catch.

Remove the front cover

Fig. 23 Remove the front cover

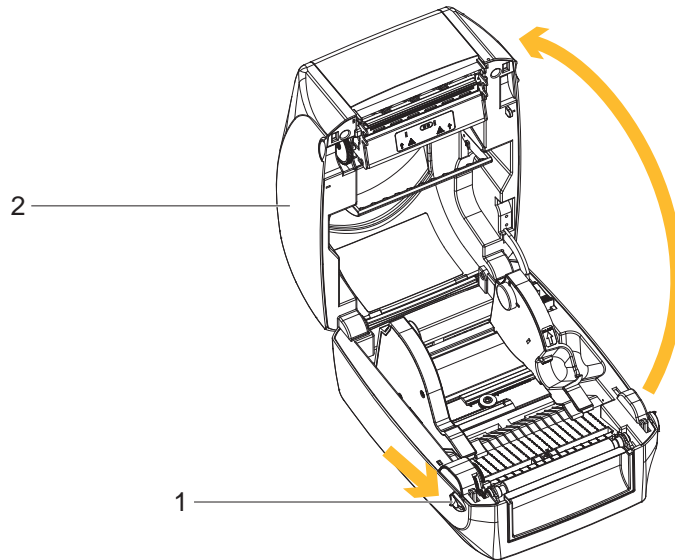
- ▶ Pull upward to remove the front cover (3).

Remove the platen

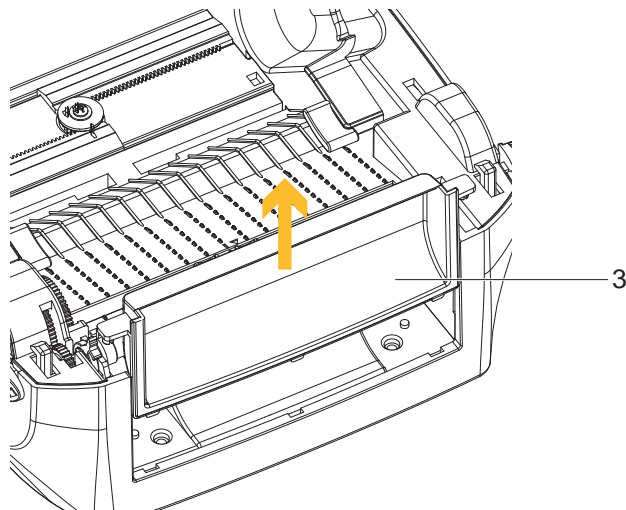
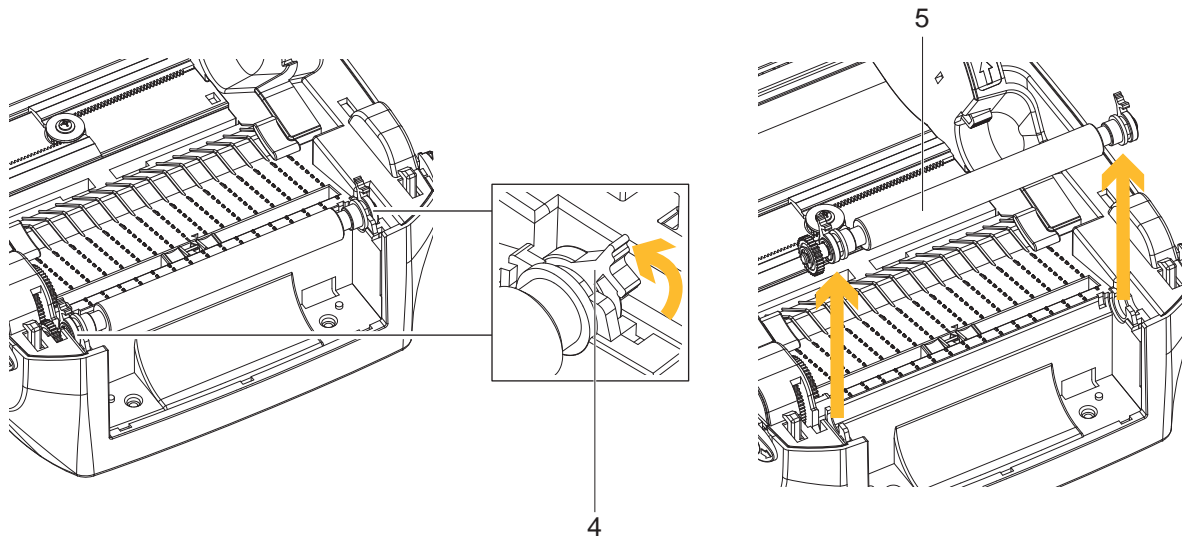

Fig. 24 Remove the platen

- ▶ Lift up the release clips (4) on both sides of the platen (5).
- ▶ Pull upward the platen (5).

**Note!****Load the ribbon and the label.**

For further information ▷ 4 on page 12.

8.2 Installing the Present Sensor



Note!

A label liner thickness of $0.006 \text{ mm} \pm 10\%$ and a weight of $65 \text{ g/m}^2 \pm 6\%$ are recommended.

The Present Sensor will take labels up to a max. width of 118 mm.

When using the Present Sensor, set the stop position (printer command ^E) to 13.

The Overview of the Label Dispenser

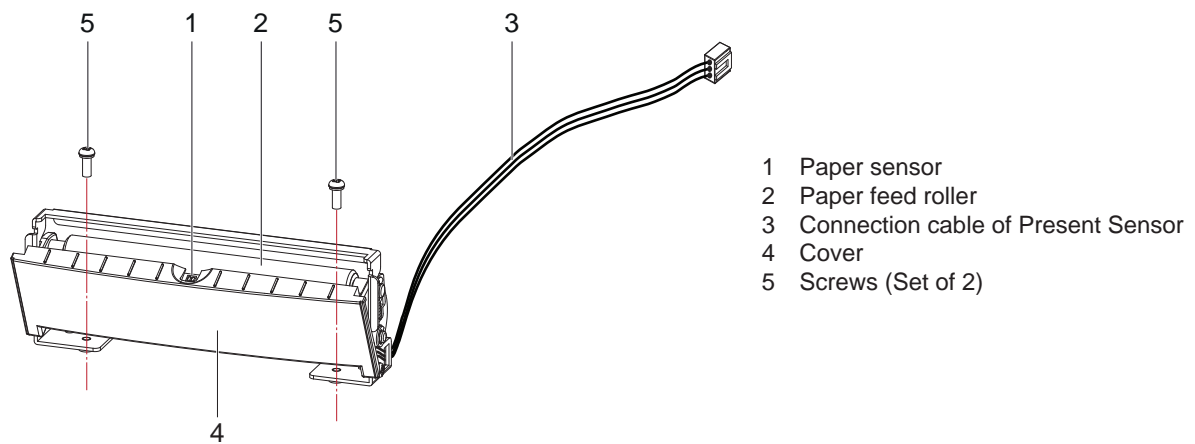

Fig. 25 Overview of the Label Dispenser

Preparation Steps



Note!

Please see the Section [▷ 8.1](#) on page 40 Preparation Steps to complete the preparation steps before installing the Present Sensor

Installing the Present Sensor

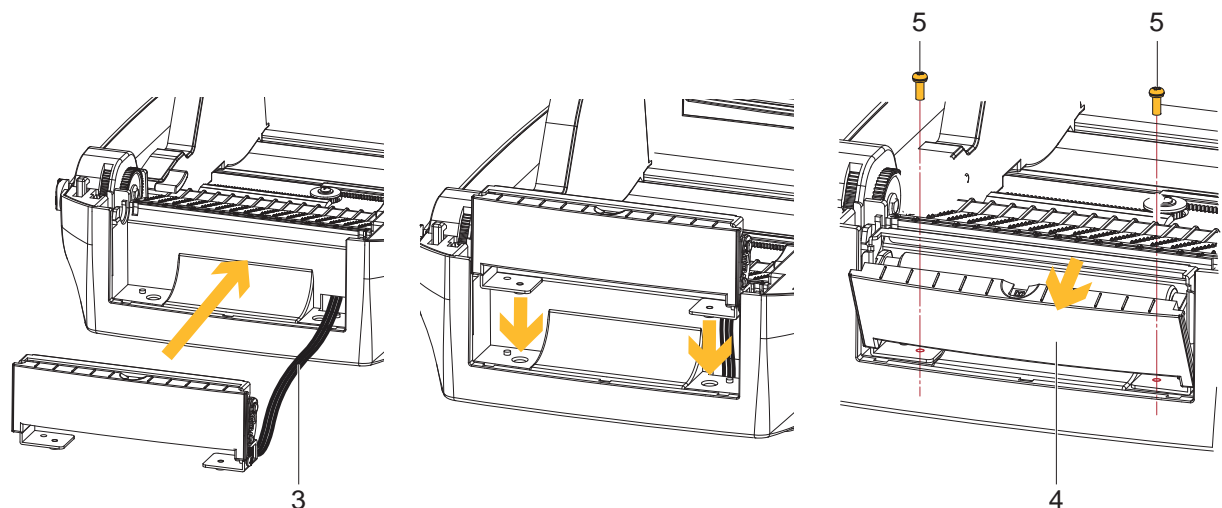

Fig. 26 Installing the Present Sensor

1. Pass the connection cable (3) through the slot of the printer.
2. Place Present Sensor to align both holes of screw at the printer.
3. Open the cover (4).
4. Tighten the screws (5).

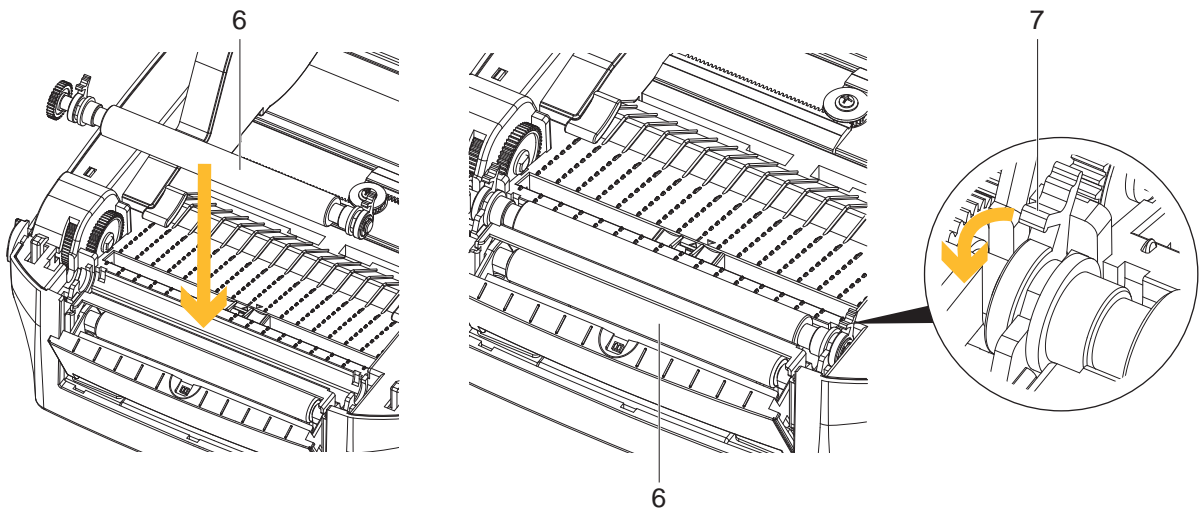

Fig. 27 Place the platen

5. Place the platen (6) back to the printer.
6. Lock the platen (6) with the clips (7) on both sides.

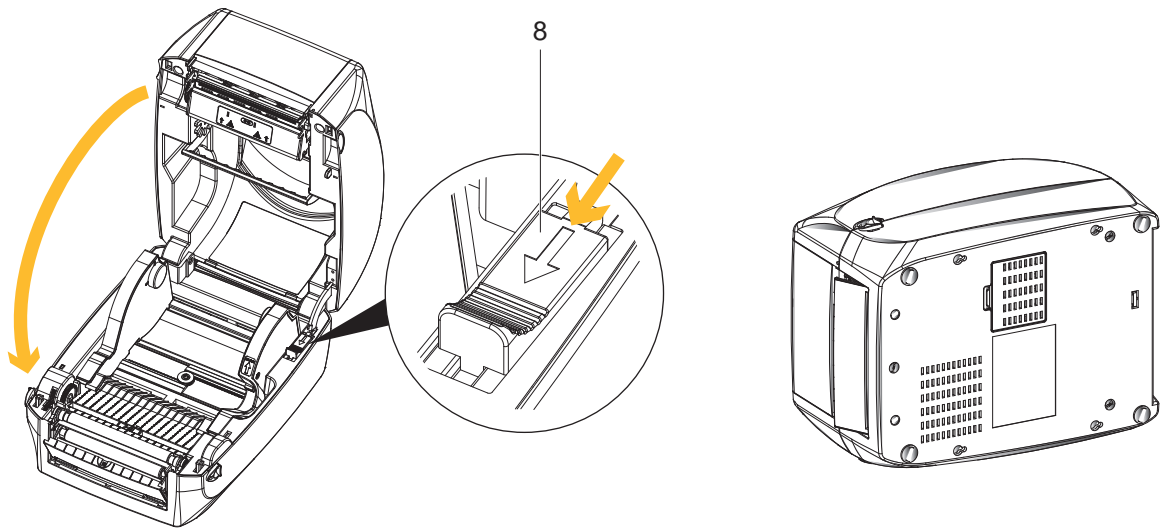

Fig. 28 Closing the and turning printer

7. Release catch for closing the printer cover (8) and close the printer.
8. Turn the printer upside down.

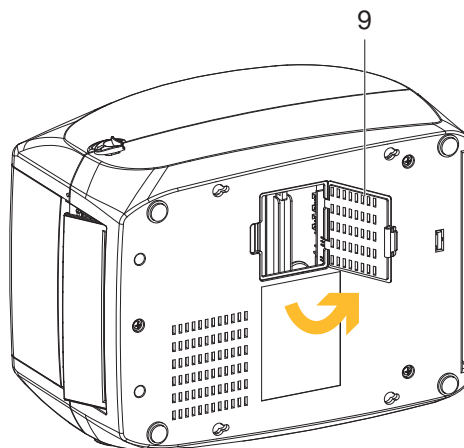

Fig. 29 Open the cover of module connection jacks

9. Open the cover of module connection jacks (9) on the bottom of printer.

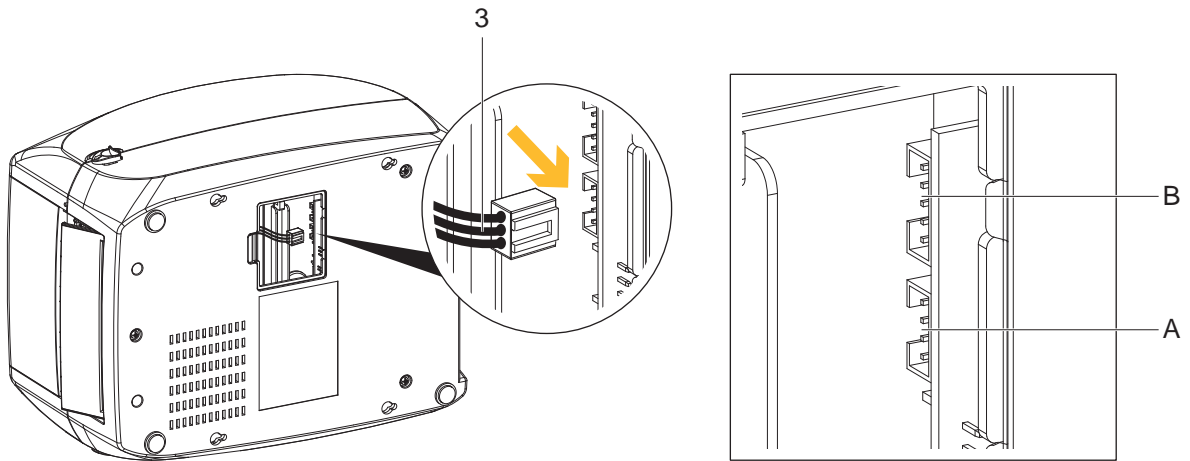

Fig. 30 Plug the connector

10. Plug the connector (3) to the Present Sensor to the lower jack (A).



Note!

There are 2 jacks : the lower jack (A) for the Present Sensor, the upper jack (B) for the cutter.

11. Close the cover of the module connection jacks on the bottom of the printer.

12. Turn back the printer into operating position.

Loading Label Roll with the Present Sensor Module

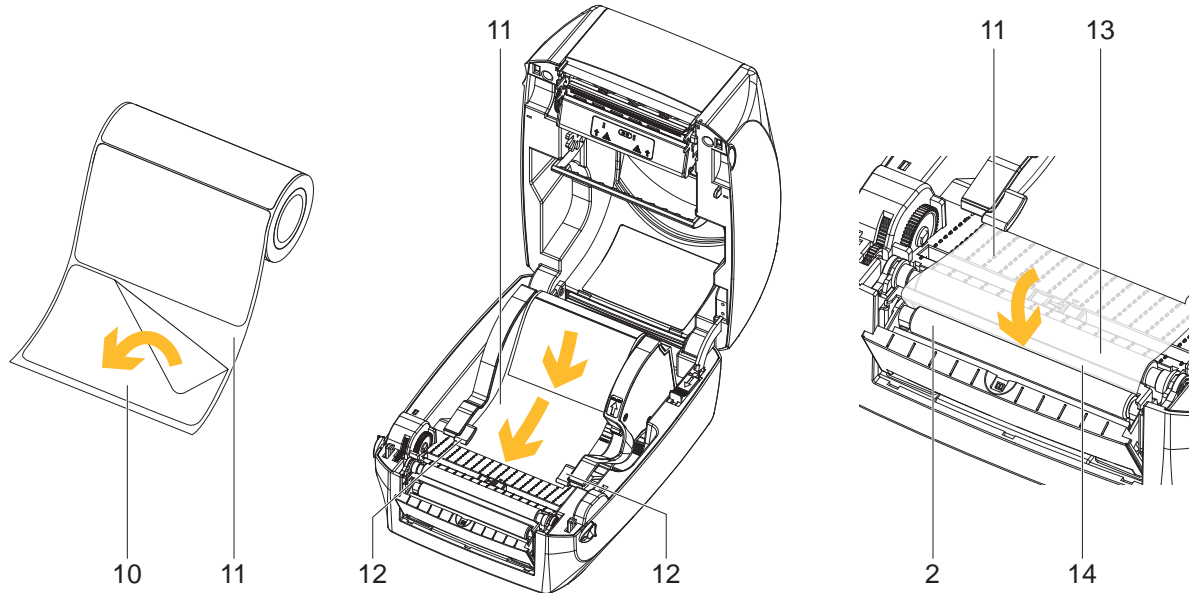

Fig. 31 Loading label roll

1. Remove the first label (10) from the label liner (11).
2. Open the printer and load the label roll ▶ 4.3 on page 15.
3. Feed the label stock (11) on both sides through the label guides (12).
4. Pull the label liner over the platen (13) and the steel (14).
5. Pull the label liner through the steel (14) and the paper feed roller (2) of the Present Sensor.

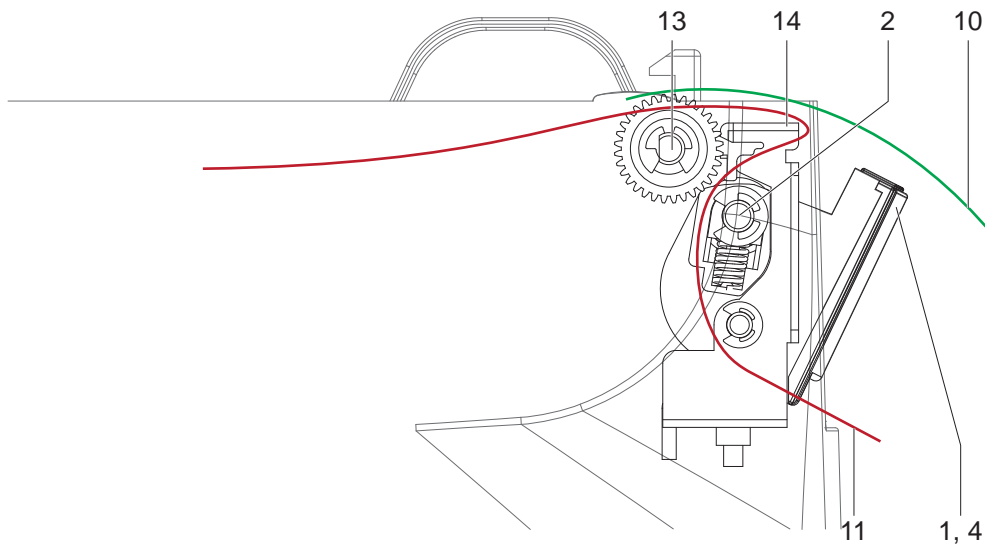

Fig. 32 Feeding path of label and liner

6. Push the label liner (11) forwards until it appears at the underside of the Present Sensor.
7. Detach two test labels (10), and feed them over the cover (4) with the paper sensor (1).

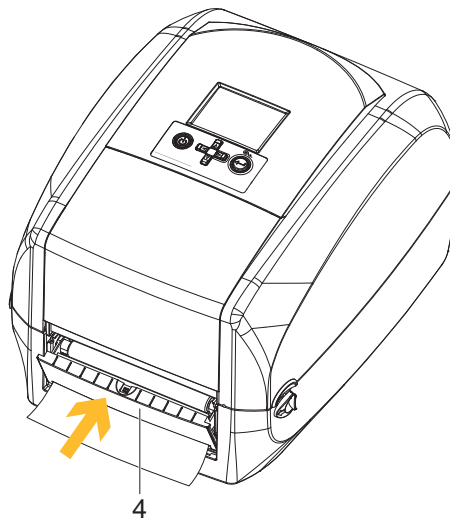

Fig. 33 Closing the cover

8. Release catch for closing the printer cover and close the printer.
9. Close the cover (4) of the Present Sensor.

Function Test

1. Switch the printer on.
2. Press the FEED button (15).
3. Label is transported forwards and detached from the backing material.

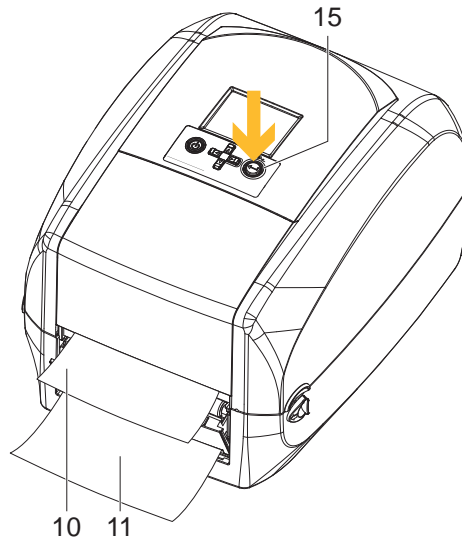

Fig. 34 Function of Present Sensor

**Note!**

The label (10) will be peeled from the liner (11) while it passes through the Present Sensor.

There is a paper sensor on the Present Sensor module. It will stop the printing if it is covered by label. Remove the last printed label and the printer will then continue to print next label.

8.3 Installing the Cutter



Note!

Do not use to cut adhesive labels! Glue residue will be left on the cutter blade and impair its functioning. You can cut paper with a max. width of 116 mm. Labels should be at least 30 mm high.

We advise against using inside wound label stock.

With the cutter installed, set the stop position to 30, and the E value to 30.

The Overview of the Cutter

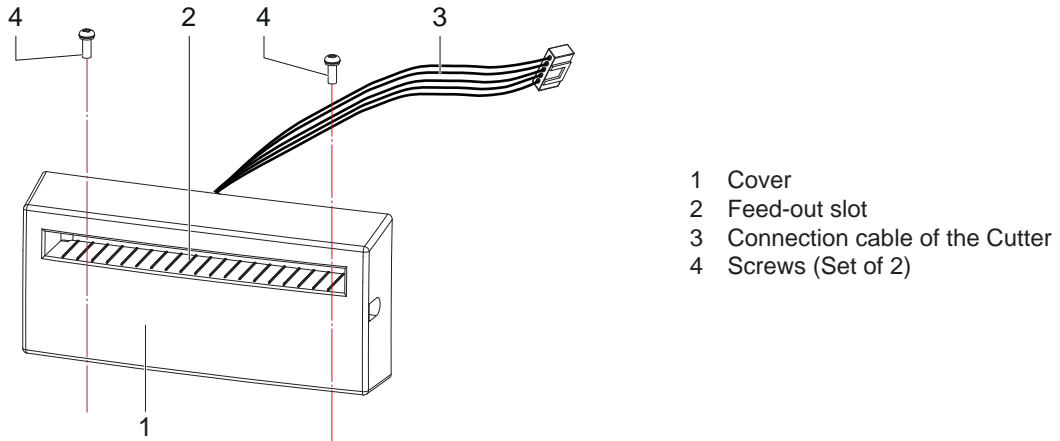

Fig. 35 Overview of the Cutter

Preparation Steps



Note!

Please see the Section ▷ 8.1 on page 40 Preparation Steps to complete the preparation steps before installing the Cutter.

Installing the Cutter

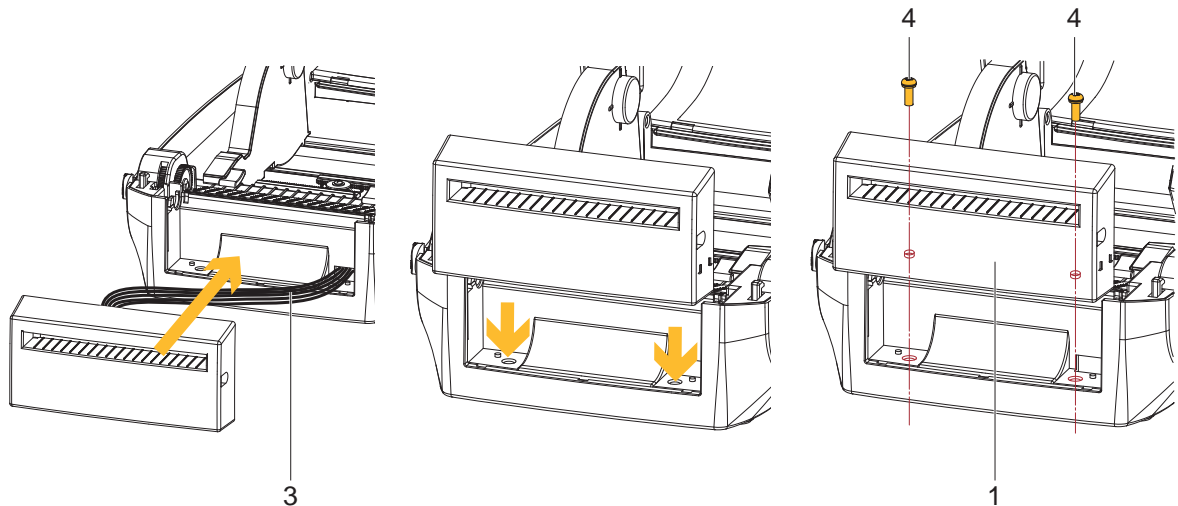

Fig. 36 Installing the Cutter

1. Pass the connection cable (3) through the slot of the printer.
2. Place the Cutter (1) to align both holes of screw at the printer.
3. Tighten the screws (4).

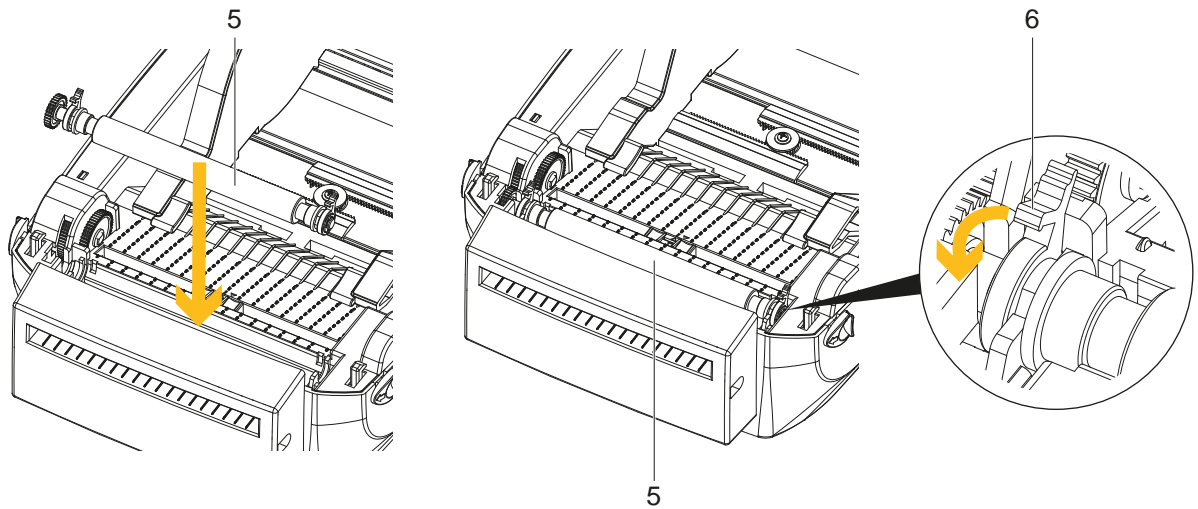

Fig. 37 Place the platen

4. Place the platen (5) back to the printer.
5. Lock the platen (5) with the clips (6) on both sides.

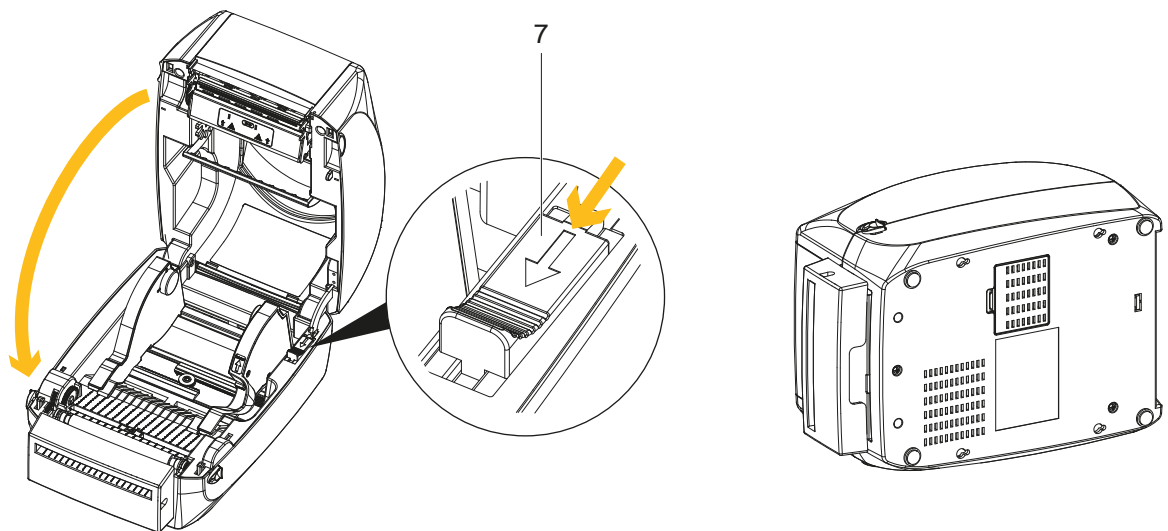

Fig. 38 Closing the and turning printer

6. Release catch for closing the printer cover (7) and close the printer.
7. Turn the printer upside down.

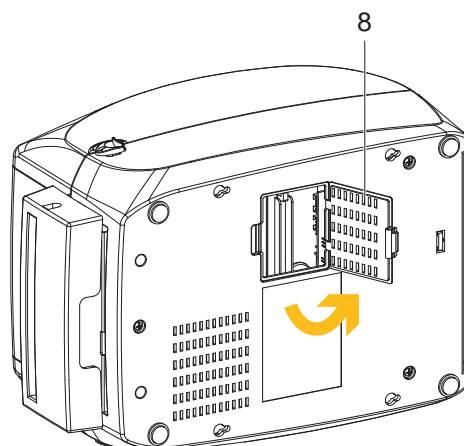

Fig. 39 Open the cover of module connection jacks

8. Open the cover of module connection jacks (8) on the bottom of printer.

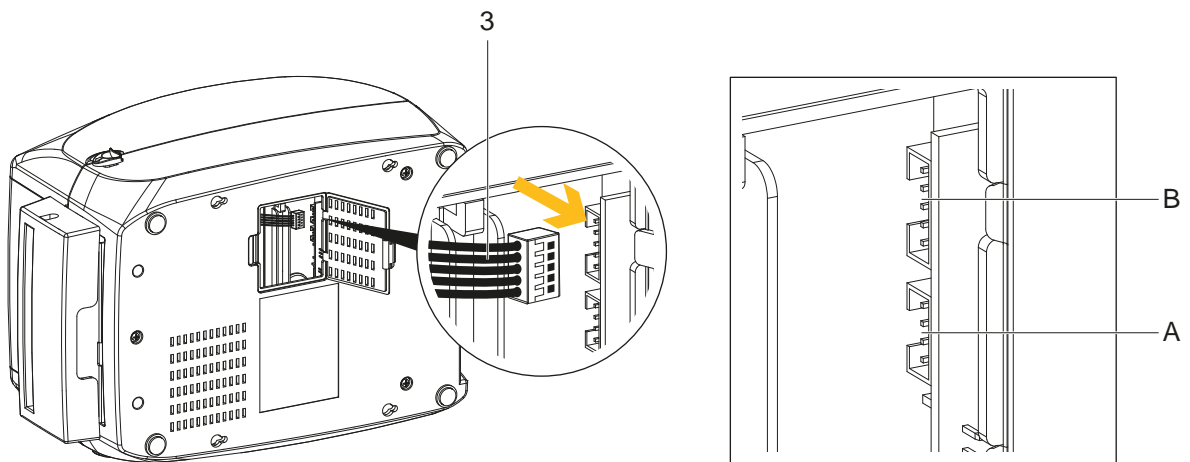

Fig. 40 Plug the connector

9. Plug the connector (3) to the Cutter to the upper jack (B).



Note!

There are 2 jacks : the lower jack (A) for the Present Sensor, the upper jack (B) for the cutter.

10. Close the cover of the module connection jacks on the bottom of the printer.

11. Turn back the printer into operating position.

Loading Label Roll with the Cutter

1. Open the printer and load the label roll ▷ 4.3 on page 15.

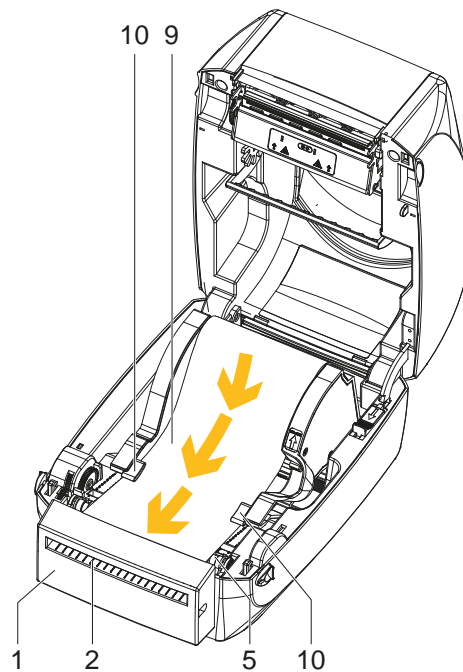

Fig. 41 Loading label roll

2. Feed the label stock (9) on both sides through the label guides (10).

3. Pull the label stock (9) over the platen (5) and through the feed-out (2) slot of the cutter (1).

4. Release catch for closing the printer cover and close the printer.

Function Test

1. Switch the printer on.
2. Press the FEED button (11) to set the label position.
3. Label is transported forwards and cut.

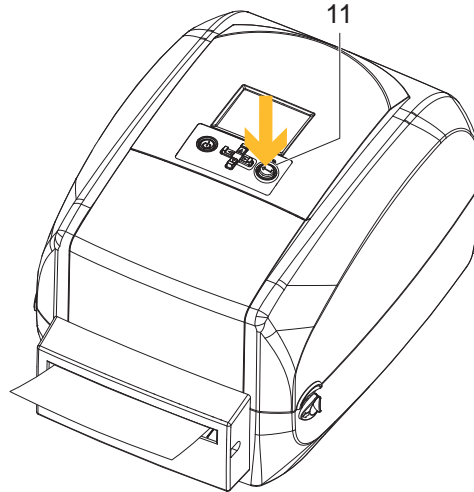

Fig. 42 Function test of the cutter

9.1 Technical Data

Label Printer ¹⁾			MACH2/200	MACH2/300
Print Head				
Printing method			Thermal transfer, direct thermal	
Printable resolution			203	300
Print speed			177	127
Print width			108	105,7
Material ²⁾				
Paper, cardboard, plastics continuous material on a roll or fanfold			■	
Width	Labels	mm	25 - 112	
	Liner continuous material	mm	25 - 118	
Label height	at least mm		4	
	up to mm		1,727	762
Thickness			0.06 - 0.2	
Weight			60 - 160	
Roll	Outer diameter	up to mm	127	
	Core diameter	mm	25.4 - 38.1	
Winding			Outside or inside	
Ribbon				
Ink side			Outside or inside	
Roll diameter			68	
Core diameter			25.4	
Variable length			300	
Width			25 - 114	
Printer size and weights				
Width x Height x Depth			210 x 186 x 280	
Weight			3	
Label sensor with position indication				
Gap sensor			Fixed at center	
Reflective sensor from below			Adjustable	
Electronics				
Storage	Flash	MB	16	
	SDRAM	MB	8 (4 MB for the application)	
Battery for current date/time, real-time clock			■	
Interfaces				
RS232C			■	
USB for PC connection			■	
Ethernet			■	
USB host			■	
Operating data				
Power supply			100 - 240 VAC ~ 50/60 Hz, PFC	
Power consumption			60	
Temperature / humidity	Operation		5 - 40°C / 30 - 85% not cond.	
	Storage		-20 - 50°C / 10 - 90% not cond.	
	Transport		-25 - 60°C / 20 - 80% not cond.	
Approvals			CE, FCC, CCC, CB, UL, KCC	

Label Printer ¹⁾		MACH2/200	MACH2/300
Operation panel			
Buttons	Feed		■
	On/Off		■
	Material sensor calibration		■
LEDs	Ready		-
	Status		-
Colored TFT display with navigator pad			■
On Display			
	Printer settings	Analysis	
	Label settings	Finish	
	Accessories	Digital clock	
Control			
	End of ribbon		
	End of material		
	Print head open		
Testing			
System diagnosis	When device is switched on, including print head detection		
Short status report, status printout	Printer settings	Analysis	
	Label settings	Finish	
	Accessories	Label calibration	
	Test printout		
Fonts			
Font types	11 bitmap fonts including OCR-A, OCR-B		
Character sets	Codepage 437, 737, 850 bis 852, 855, 857, 860 bis 863, 865, 866, 869 Windows 1250 to 1255, 1257		
Bitmap fonts	Zoom factor up to eight times width and height; orientation 0°, 90°, 180°, 270°		
Graphic formats			
	PCX, BMP		
Barcodes			
1D codes	Code 39	UCC/EAN 128 Kmart	
	Code 9	Random Weight	
	EAN 8, 13 (Add-ons 2 und 5)	Post NET	
	UPC A, E (Add-ons 2 und 5)	ITF 14	
	Interleaved 2/5 (with Shipping Bearer Bars)	China Postal Code	
	Codabar	HIBC	
	Code 128 A, B, C	MSI	
	EAN 128	Plessey	
	RPS 128	Telepen	
	UCC 128	FIM	
		GS1 DataBar	
2D codes	PDF417	Micro PDF417	
	DataMatrix	Micro QR-Code	
	MaxiCode	Aztec	
	QR-Code		

Label Printer ¹⁾		MACH2/200	MACH2/300
Software			
Printer languages	EZPL, ZPL, EPL		■
Label software	cablabel S3 Lite		■
	cablabel S3 Viewer		■
	cablabel S3 Pro		□
Windows drivers certified 32/64 bit for	Windows Vista	Server 2003	■
	Windows 7	Server 2008	
	Windows 8	Server 2008 R2	
	Windows 8.1	Server 2012	
	Windows 10	Server 2012 R2	

Table 6 Technical Data

- Standard
- Option

¹⁾ All information on the design and technical specifications correspond to the date of the printing. Subject to change. For current data see website www.cab.de/labelprinter.

²⁾ Limitations may apply to small labels, thin materials or strong adhesives. These applications need to be tested and approved.

9.2 Interface

Pinout Description

- **USB**

Connector Type: Type B

Pin No.	1	2	3	4
Function	VBUS	D-	D+	GND

Table 7 Pinout description USB Interface

- **Serial Port**

Default settings:

Baud rate 9600, no parity, 8 data bits, 1 stop bit, XON/XOFF protocol and RTS/CTS

RS232 Housing (9-pin to 9-pin)		
DB9 Socket		DB9 Plug
-	1__1	+5 V, max. 500 mA*
RXD	2__2	TXD
TXD	3__3	RXD
DTR	4__4	N/C
GND	5__5	GND
DSR	6__6	RTS
RTS	7__7	CTS
CTS	8__8	RTS
RI	9__9	N/C
Computer	-	Printer

Table 8 Pinout description Serial Port

* The total current to the serial port may not exceed 500 mA.

9.3 Reference to the EU Declaration of Conformity

The printers of the MACH series comply with the relevant fundamental regulations of the EU Rules for Safety and Health:

- Directive 2014/35/EU relating to electrical equipment designed for use within certain voltage limits
- Directive 2014/30/EU relating to electromagnetic compatibility
- Directive 2011/65/EU on the restriction of the use of certain hazardous substances in electrical and electronic equipment

EU Declaration of Conformity

▷ <https://www.cab.de/media/pushfile.cfm?file=2836> 



9.4 FCC

NOTE : This equipment has been tested and found to comply with the limits for a Class A digital device, pursuant to Part 15 of the FCC Rules. These limits are designed to provide reasonable protection against harmful interference when the equipment is operated in a commercial environment. The equipment generates, uses, and can radiate radio frequency and, if not installed and used in accordance with the instruction manual, may cause harmful interference to radio communications. Operation of this equipment in a residential area is likely to cause harmful interference in which case the user may be required to correct the interference at his own expense.

A

Accessories40

B

Box Content.....6

C

cablabel S3.....18

Cleaning37

Configuration19

Cutter.....40, 47

E

Environment5

Error Alerts.....38

Ethernet Port7

Ethernet Setting.....28

F

FEED Button.....7, 16, 21

Fonts.....52

Function Test16, 46, 50

G

Graphic formats.....52

I

Important information.....4

Intended use.....4

Interface.....53

L

Label Calibration.....36

Label guide plates15

Labeling Software.....18, 53

Label Roll.....44, 49

Label sensor.....51

Label Stock.....15

LCD Display.....7, 11, 21

LCD Password.....30

LED Power7

LED Status7

Leporello labels16

Lithium battery.....5

Loading Material.....12

M

Mach1/2-Load.....19

Main Page23, 27

Material.....51

N

Navigator Pad.....7, 21

O

Operation Panel.....21, 52

Overview.....6

P

Platen41, 43, 48

POWER Button.....7, 11, 21

Power cord6

Power plug.....10

Power Supply10, 51

Present Sensor.....40, 42

Printer Driver17

Print Head.....37, 51

Printing Mechanism.....9

R

Ribbon12, 51

Ribbon Rewind Module14

Ribbon Supply Module13

S

Safety Instructions.....5

Self Test.....35

Serial Port.....7, 53

Service work.....5

Setting Items.....33

Setting Mode33

Set up printer6

Software17

Supply voltage.....10

Switching on11

System diagnosis52

T

Temperature51

Troubleshooting.....39

U

Unpacking.....6

USB Port.....7, 53

V

Voltage.....5

W

Warning stickers5

Weight51

Windows drivers53